

H2020-SC6-GOVERNANCE-2018-2019-2020

DT-GOVERNANCE-05-2018-2019-2020



D4.4: Micro Proxies and services catalogue – Initial

Project Reference No	959157 — ACROSS — H2020-SC6-GOVERNANCE-2018-2019-2020
Deliverable	D4.4: Micro Proxies and services catalogue – Initial
Work package	WP4 - ACROSS Modules Set-Up
Nature	Other
Dissemination Level	Public
Date	31/01/2022
Status	V1.0
Editor(s)	Vincenzo Savarino (ENG)
Contributor(s)	Anestis Sidiropoulos (ATC), Enrique Areizaga (TEC), Valentín Sánchez (TEC)
Reviewer(s)	Timo Behrmann (DATAPORT), Thilo Ernst (FRH)
Document description	This report focuses on the initial design and implementation of components of <i>Harmonization and connectors layer</i> of ACROSS architecture. It documents the requirements, functional specification, design, description of modules, and description of components APIs. It also describes the respective initial PoCs delivered together with this report.



About

The project is co-funded by the European Commission's Horizon 2020 research and innovation framework programme. Spanning through three years, ACROSS consists of a consortium of 10 partners from 7 countries: Athens Technology Center (coordinator), Tecnalia, Dataport, Engineering, Fraunhofer, GRNET, TimeLex, The Lisbon Council, Waag and VARAM. The project kicked off its activities in February 2021, with an energising online meeting, where all partners took the floor to present their plans to make the project a great success.

DISCLAIMER

The information and views set out in this publication are those of the author(s) and do not necessarily reflect the official opinion of the European Commission. The Commission does not guarantee the accuracy of the data included in this study. Neither the Commission nor any person acting on the Commission's behalf may be held responsible for the use, which may be made of the information contained therein.

© 2021 – European Union. All rights reserved. Certain parts are licensed under conditions to the EU.



Document Revision History

Version	Date	Modifications Introduced	
		Modification Reason	Modified by
V0.1	29/10/2021	Table of contents	ENG
V0.2	05/11/2021	Modification of ToC	ENG
V0.3	22/11/2021	Contribution on Service Catalogue model	TECNALIA
V0.4	03/12/2021	Added ACROSS Service model Annex I	ENG
V0.5	18/12/2021	Added section 2.3 and Annex II	ENG
V0.6	14/01/2022	Pre-release ready for internal review	ENG
V0.7	24/01/2022	Feedback and revision	DATAPORT, FHR
V1.0	27/01/2022	Final release	ENG



Executive Summary

The main objective of the ACROSS project is to provide the means (tools, methods and techniques) to enable user-centric design and implementation of interoperable cross-border (digital) public services compliant with the current European regulations (e.g. the Single Digital Gateway (SDG) and Once-Only principle (OOP), European Interoperability Framework (EIF)) where the private sector can also interconnect their services **while ensuring the data sovereignty of the citizens, who can set the privacy level that will allow the public and private sector to access to their data based on their requirements.**

This report documents the result of activities performed in Task 4.2" Public & Private sector offerings management tool" describing the initial release of Service Catalogue components and related service proxy adapters.



Table of Contents

1	INTRODUCTION	10
1.1	PURPOSE AND SCOPE	10
1.2	APPROACH FOR WORK PACKAGE AND RELATION TO OTHER WORK PACKAGES AND DELIVERABLES	11
1.3	METHODOLOGY AND STRUCTURE OF THE DELIVERABLE	11
2	DATA HARMONIZATION AND CONNECTORS	12
2.1	ACROSS CONTEXT AND ARCHITECTURE OVERVIEW	12
2.2	SERVICE MODEL	17
2.2.1	<i>Information view</i>	18
2.2.2	<i>Usage Rule and Personal Data Handling views</i>	20
2.2.3	<i>Service Instance view</i>	22
2.3	SERVICE CATALOGUE	22
2.3.1	<i>Service Manager</i>	26
2.4	SERVICE ADAPTER AND BASELINE TECHNOLOGIES	33
2.4.1	<i>Data Model Mapper</i>	33
2.4.2	<i>IDS Data Connector</i>	34
3	CONCLUSIONS AND NEXT STEPS	36
4	REFERENCES	37
5	ANNEX I - ACROSS SERVICE MODEL	38
5.1	SERVICE MODEL CLASS DIAGRAM	39
5.2	SERVICE BASIC INFO	40
5.3	SERVICE INFORMATION SECTION	41
5.4	SERVICE INSTANCE	45
5.5	CONNECTOR	48
5.6	DATASET	49
5.7	SERVICE PERSONAL DATA HANDLING SECTION	50
5.8	SERVICE DATA USAGE SECTION	54
5.9	SERVICE MODEL JSON SCHEMA	54
5.10	SERVICE MODEL JSON-LD CONTEXT	56
6	ANNEX II - SERVICE CATALOGUE APIS	64
7	ANNEX III - ACROSS REQUIREMENTS MAPPING	65



List of Figures

FIGURE 1 - ACROSS CONCEPTUAL APPROACH AND MAIN COMPONENTS SUPPORTING USER CENTRIC CROSS-BORDER MOBILITY SERVICE DELIVERY.	10
FIGURE 2 - CONCEPTUAL ARCHITECTURE OF ACROSS	12
FIGURE 3 - SERVICE ADAPTERS AND CATALOGUE. FOR EACH SERVICE USED BY ACROSS PLATFORM A SERVICE ADAPTER IS DEFINED AND RELATED INFORMATION IS STORED IN THE SERVICE CATALOGUE.....	13
FIGURE 4 - ARCHITECTURE OF ACROSS PLATFORM FROM [1]	14
FIGURE 5 - MAIN COMPONENTS OF DATA HARMONIZATION AND CONNECTORS. EACH COMPONENT IS INVOLVED IN THE FLOW ACCORDING TO THE TYPE OF ADAPTATION PERFORMED.....	14
FIGURE 6 - MODULES INVOLVED (AND RELATED FLOW) IN SERVICE MODEL ADAPTATION	15
FIGURE 7 - MODULES INVOLVED (AND RELATED FLOW) IN SERVICE INVOCATION ADAPTATION	16
FIGURE 8 - SERVICE CATALOGUE AND SERVICE ADAPTED MODULES INTERACTION MAP WITH OTHER MODULES OF ACROSS PLATFORM. .	17
FIGURE 9 - GRAPHICAL REPRESENTATION OF THE SERVICE MODEL MAIN CLASSES ADOPTED IN ACROSS.....	17
FIGURE 10 - GRAPHICAL REPRESENTATION OF THE RELATIONSHIPS BETWEEN THE CLASSES AND PROPERTIES OF THE FULL CORE PUBLIC SERVICE VOCABULARY APPLICATION PROFILE (FIGURE FROM [2]).....	19
FIGURE 11 - IDS CONTRACT AGREEMENT	20
FIGURE 12 - CLASS DIAGRAM OF PERSONAL DATA HANDLING MODEL AS PROFILE OF DATA PRIVACY VOCABULARY (DPV)	21
FIGURE 13 - MAIN MODULES IMPLEMENTED BY THE SERVICE CATALOGUE	23
FIGURE 14 - FRONT-END AND BACKEND OF SERVICE CATALOGUE IMPLEMENTATION	24
FIGURE 15 - ADOPTED TECHNOLOGIES IN SERVICE CATALOGUE IMPLEMENTATION	24
FIGURE 16 - INTERACTION OF SERVICE CATALOGUE WITH KEYCLOAK FOR IDENTITY AND ACCESS MANAGEMENT	25
FIGURE 17 - IDENTITY BROKERING FLOW SUPPORTED BY KEYCLOAK	26
FIGURE 18 - THE SERVICE MANAGER ADMIN DASHBOARD PROVIDES A MODULAR WEB INTERFACE TO INTERACT WITH SEVERAL LAYERS OF ACROSS PLATFORM.....	27
FIGURE 19 - AUTHENTICATION PAGE OF SERVICE MANAGER.....	27
FIGURE 20 - SERVICE LIST PAGE	28
FIGURE 21 - AVAILABLE ACTIONS IN ACCORDANCE TO THE STATUS OF SERVICE	28
FIGURE 22 - EXPORT DIALOG	29
FIGURE 23 - SERVICE EDITOR PAGE	30
FIGURE 24 - IMPORT DIALOG	31
FIGURE 25 - CONNECTORS LIST PAGE.....	31
FIGURE 26 - CONSENT REGISTRY PAGE	32
FIGURE 27 - DASHBOARD PAGE.....	32
FIGURE 28 - IDS CONNECTOR INTERACTIONS	34



FIGURE 29 - TRUE CONNECTOR ARCHITECTURE AND INTERACTIONS35
FIGURE 30 - COMPLETE CLASS DIAGRAM OF SERVICE MODEL39
FIGURE 31 - DOCUMENTATION OF THE API OF SERVICE CATALOGUE64

List of Tables

TABLE 1 BASIC INFO PROPERTIES OF SERVICE MODEL CLASS40
TABLE 2 - SERVICE INFORMATION CLASS41
TABLE 3 - SERVICE INSTANCE CLASS46
TABLE 4 - CONNECTOR CLASS48
TABLE 5 - DATASET CLASS49
TABLE 6 - PERSONAL DATA HANDLING CLASS50
TABLE 7 - DATA USAGE CLASS54



List of Terms and Abbreviations

Abbreviation	Definition
API	Application Programming Interface
CH	Clearing House
CPSV-AP	Core Public Service Vocabulary Application Profile
DAPS	Dynamic Attribute Provisioning Service
DCAT	Data Catalog Vocabulary
DPV	Data Privacy Vocabulary
ECC	Execution Core Container
eIDAS	electronic Identification, Authentication and trust Services
EIF	European Interoperability Framework
ELI	European Legislation Identifier
EU	European Union
GDPR	General Data Protection Regulation
HTTPS	Hypertext Transfer Protocol Secure
ID	Identification
IDS	International Data Spaces
IDSCP	International Data Spaces Communication Protocol
ISA2	Interoperability solutions for public administrations, businesses and citizens
ISO	International Organization for Standardization
JPA	Java Persistence API
JSON	JavaScript Object Notation



Abbreviation	Definition
JSON-LD	JavaScript Object Notation Linked Data
JWT	JSON Web Token
OAuth2	Open Authorization 2.0
ODRL	Open Digital Rights Language
OOP	Once Only Principle
PA	Public Administration
PoC	Proof of Concept
RAM	Reference Architecture Model
REST	Representational state transfer
SDG	Single Digital Gateway
SME	Small Medium Enterprise
SSO	Single Sign On
ToC	Table of Content
UC	Usage Control
URI	Universal Resource Identifier
URL	Universal Resource Locator
WP	Work Package
WS	Web Socket

1 Introduction

1.1 Purpose and Scope

The main goal of ACROSS is provide a holistic solution that allows public administrations to deliver a user-centric interoperable cross-border mobility service compliant with the current European regulations where the private sector can also interconnect their services while ensuring the data sovereignty of the citizens. To this end, one of the ACROSS objectives is to provide a **set of connectors and data harmonization tools** that will facilitate the actual interoperability of the cross-border mobility services through the connection of public services so that they can interoperate with services from other countries as well as with those of the private sector also to include their services and offerings.

The ACROSS solution aims to provide a common semantic and functional stratum enabling cross border access to data and processes backed up by functionalities and capabilities for data collection and harmonisation according to a set of common and shared data models based on European standards such as Core Public Service Vocabulary¹, Core Person Vocabulary² and DCAT for metadata³.

The adoption of customizable connectors will provide proxy functionalities to connect and access public/private services offered by both the Public Administration and third parties and to get data from heterogeneous sources such as repositories, existing systems (e.g. owned by PA), etc. that could expose different interfaces.

To this aim, these customizable adapters will offer a set of software components ready to be used or tailored according to specific needs and requirements to allow the connection of data

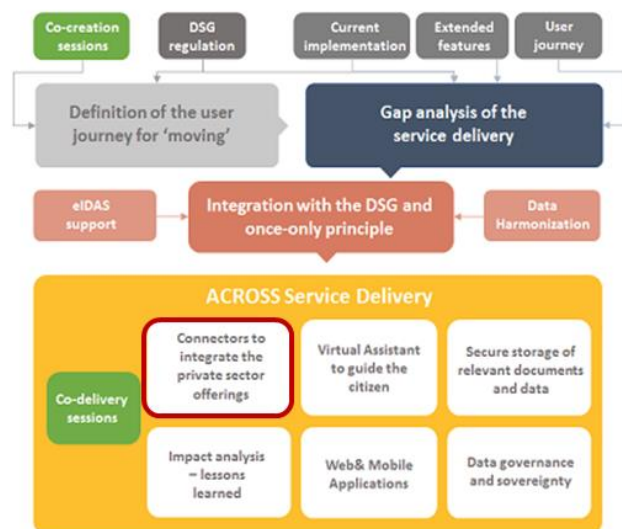

Figure 1 - ACROSS Conceptual approach and main components supporting user centric cross-border mobility service delivery.

¹<https://joinup.ec.europa.eu/collection/semantic-interoperability-community-semic/solution/core-public-service-vocabulary>

²<https://joinup.ec.europa.eu/collection/semantic-interoperability-community-semic/solution/core-person-vocabulary/release/100>

³ <https://www.w3.org/TR/vocab-dcat-2/>



sources and public/third-party private services to ACROSS Platform for the provisioning of cross-border mobility service delivery (Figure 1).

1.2 Approach for Work Package and Relation to other Work Packages and Deliverables

WP4 aims to provide a set of tools and technological solutions that implements the borders of ACROSS Platform; in details, these tools and solutions will concern: authentication aspects compliant with eIDAS, user support tools to facilitate both the interaction of the citizens with User Journey Services and connection to public and private sector services.

The services and tools developed in this WP will be integrated into the platform created in WP5 and will demonstrate the functionality of the use cases in WP6. To this end, the approach followed by this WP was to identify firstly the main building blocks, capabilities, interfaces and interactions which will satisfy the identified functional and non-functional requirements as documented in deliverable *D5.1 System Architecture & Implementation Plan – Initial*. In turn, the information documented in D5.1 is the basis for the concrete implementation of the specific architectural components.

The outcomes and the implementation of components presented in this deliverable are a subject to continuous refinements and modifications, based on the progress of all technical work packages (WP3, WP4, WP5), as well as the validation and evaluation phases.

1.3 Methodology and Structure of the Deliverable

This deliverable aims to report the outcomes of the initial implementation of data harmonization and connectors layer of ACROSS platform. To this end the deliverable has been structured in the following sections:

Section 2 describes the initial release of components of Data harmonization and connector layer of ACROSS solution and its relation with ACROSS architecture components. In particular the defined service model to support interoperability is described and the initial release of Service Catalogue. Finally, the section provides the baseline technologies that the implementation of connectors will take in to consideration.

Section 3 describes the next steps according to the initial implementation.

Annexes provides detailed information about the defined service model and the APIs exposed by the Service Catalogue. Finally, Annex III provides a mapping of covered requirements as identified in D5.1.

2 Data harmonization and connectors

The following sections provide the technical context and details of the design and implementation of the main components of Data harmonization and connectors layer in line with the ACROSS architecture as documented in D5.1.

2.1 ACROSS context and architecture overview

The following Figure 2 provides a conceptual view of ACROSS architecture by identifying the related layers and actors.

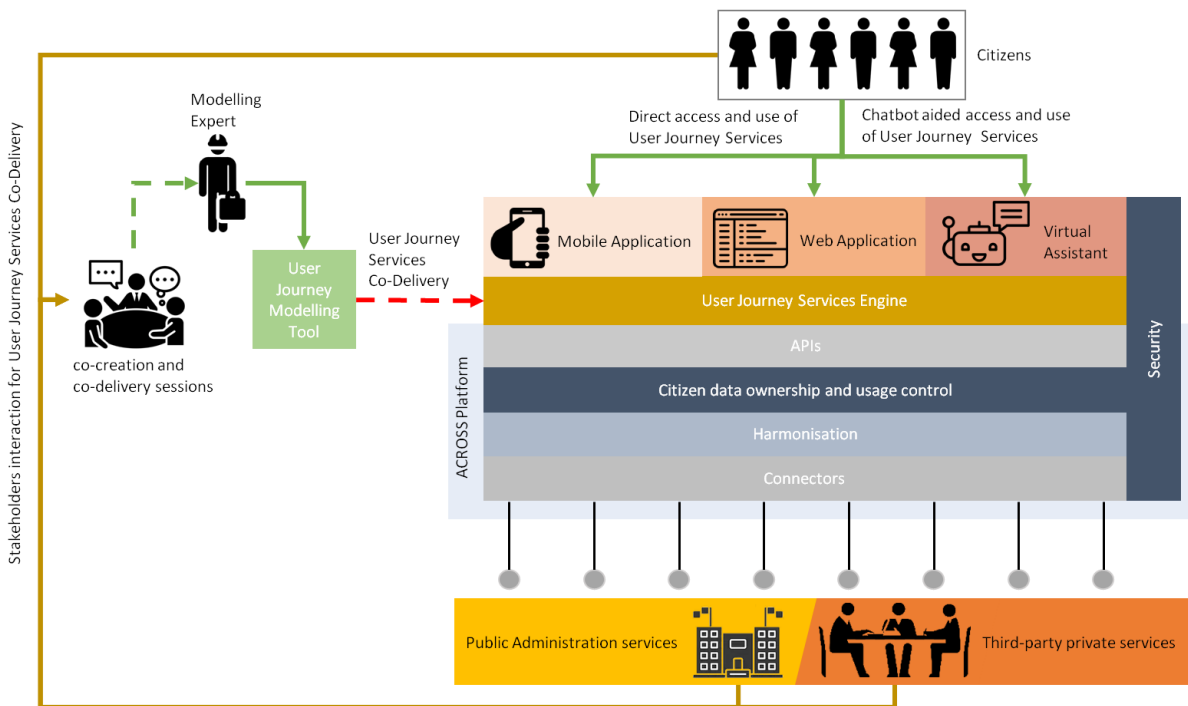

Figure 2 - Conceptual architecture of ACROSS

In particular the **Harmonization and Connectors** layers provide the south bound connection with external systems and services from public and private sectors to provide a uniform description of the services and the related invocation. To this end these layers should provide for each identified service a service adapter (Figure 3), that is a **single instance of adaptation** of that service (public & private) for its use in ACROSS Platform from several points of view for its use in the upper layers: **informational, data governance and service invocation**. To support that adaptation, Harmonization and Connectors layers should include a service catalogue with the aim to provides all functionality to register, model, map and publish and manage an uniform and harmonized machine-readable description of public and private services, according to the three

above points of view, needed to support the uses of each service by the upper layers of ACROSS Platform.

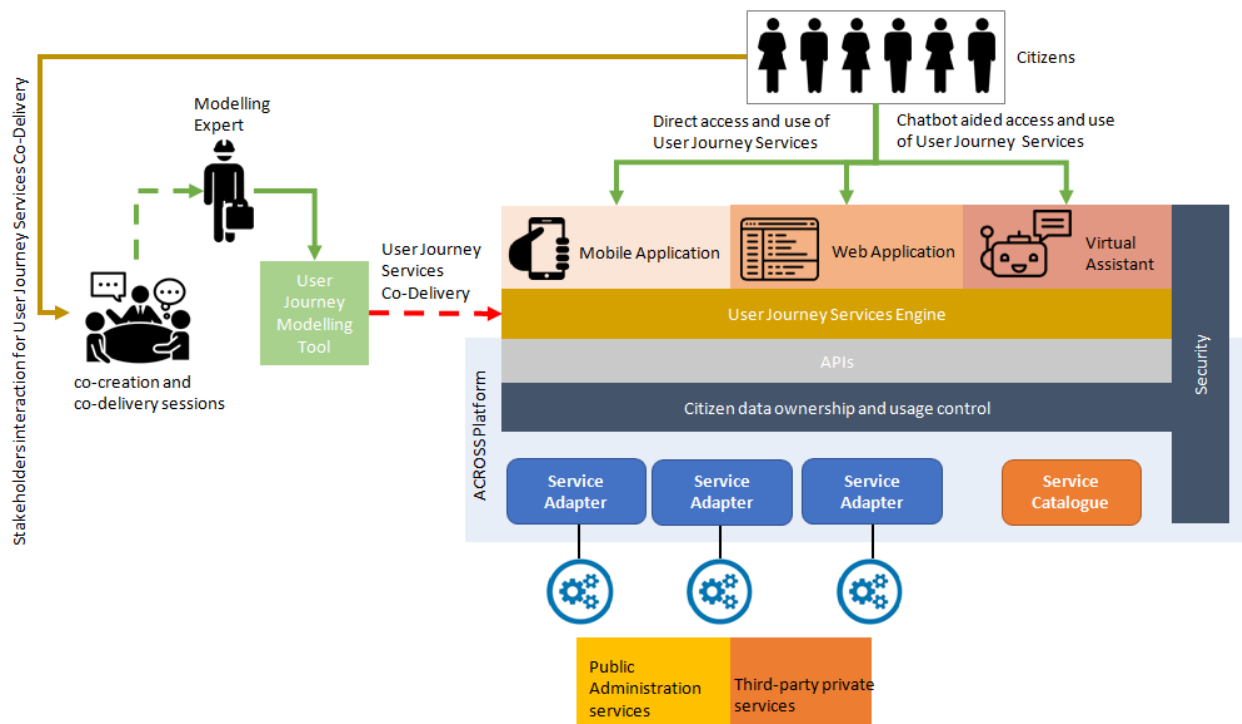

Figure 3 - Service Adapters and Catalogue. For each service used by ACROSS Platform a service adapter is defined and related information is stored in the Service Catalogue.

In the definition of ACROSS architecture (Figure 4), the upper conceptual layers have been included in the Data Harmonization and connectors main components blocks, namely **Service adapter** and **Service Catalogue** (Figure 5), to provide the following features:

- Secure connection to internal system of the PAs and services.
- Secure connection to private services to support cross border services.
- Uniform API for data access.
- Exposure of sub-set of existing functionalities/services of PAs and private
- Data access management based on authentication, authorization and privacy management for requested information.
- Semantic adaption to support interoperability according to common vocabularies
- Catalogue of services instances, models and metadata registry

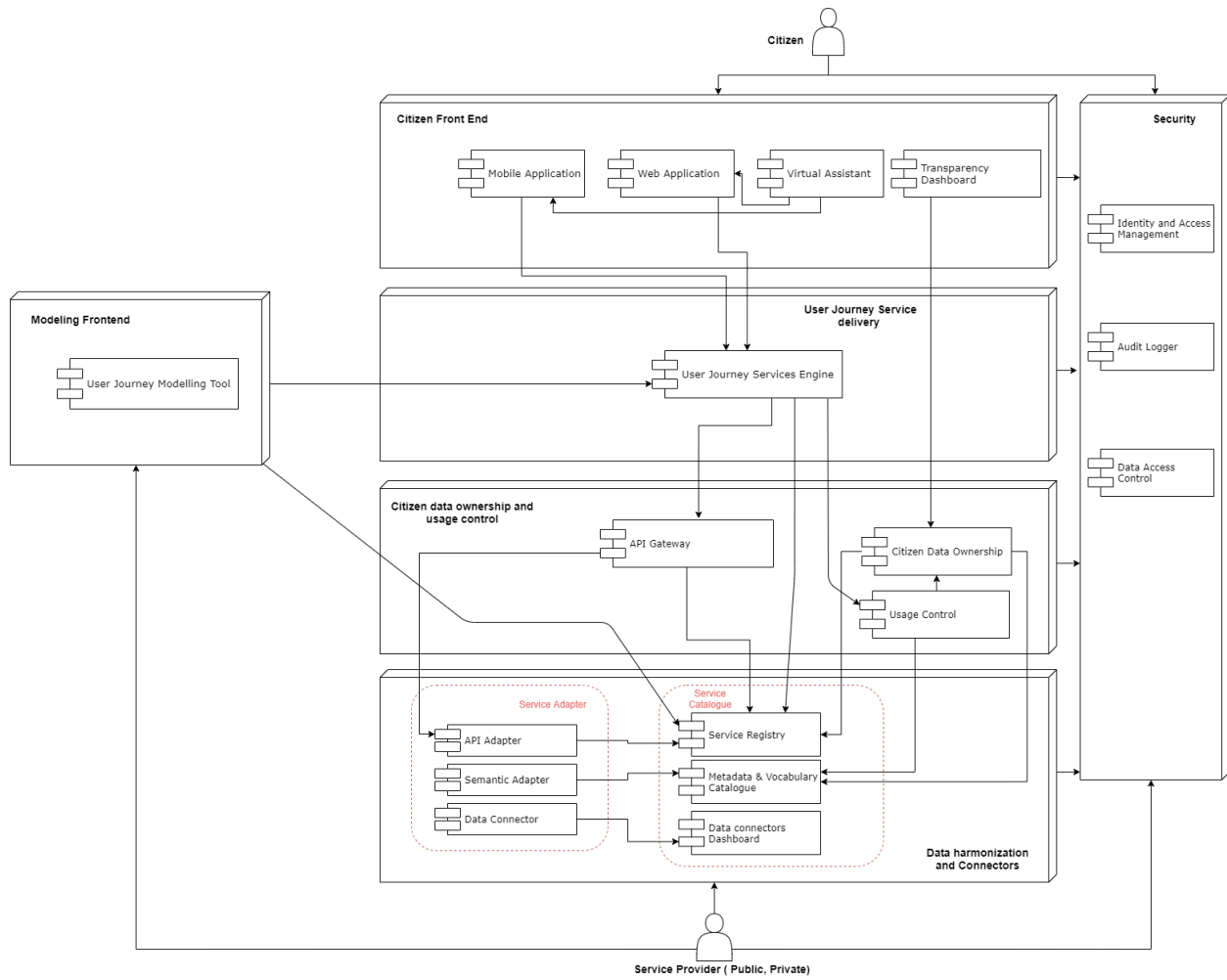

Figure 4 - Architecture of ACROSS Platform from [1]

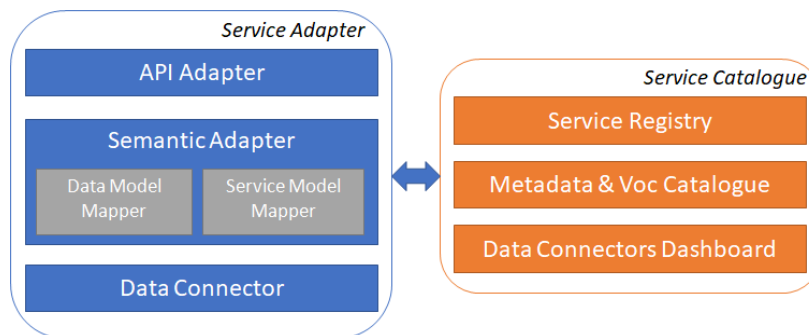

Figure 5 - Main components of Data harmonization and connectors. Each component is involved in the flow according to the type of adaptation performed

The **API Adapter** module is responsible to expose a standard set of APIs for data access (by means of data connectors) or functionalities supplied by internal or legacy systems of PAs and private service providers. API adapter is used by the API gateway to invoke all services included in the User Journey Service Engine. The **Semantic adapter** contributes in the service adaptation, through the Data Model Mapper, in order to supply data gathered from Data Connector in the expected format or, through the Service Model Mapper, to the semantic adaptation of service descriptions according to the standard and shared model adopted by the Service Catalogue. The **Data Connector** is actually the module that performs the technical integration of Legacy/Proprietary systems. Each instance of service adaptation has an ad-hoc developed data connector accordingly to the type of integration (e.g. read from API, read csv or json file or other files, read from SQL or NoSQL databases, etc.), covering also all the security aspects of authentication and authorization.

The above Service adapter modules are supported by the Service Catalogue by storing all the needed information or produced by the service adaptation modules to be consumed by the upper layers. The front-end and business layer of the Service Catalogue is the **Service Registry**, responsible to provide APIs for programmatically interaction and dashboards and graphical editors. The backend part is performed by the **Metadata and Vocabulary Catalogue**. Finally the Data Connector Dashboards module provides a management cockpit of all available data connectors instances.

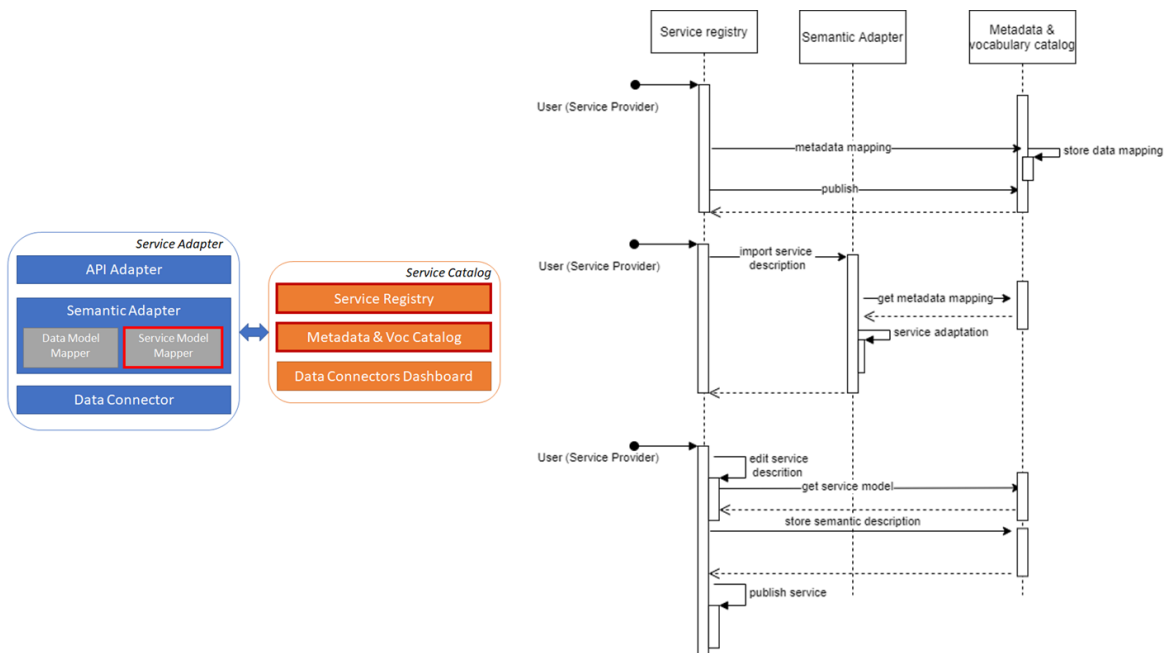

Figure 6 - Modules involved (and related flow) in Service model adaptation

Each component and related sub modules are invoked in relation to the type of service adaptation and the interaction with the upper layers. For example, the Semantic Adapter component can be invoked in order to provide functionalities for the provisioning of a common information model of the service registered to the platform. (i.e CPSV, see sections 2.2 and 2.3) (Figure 6), or used to support the interaction of ACROSS platform with an external service by defining a data connector and related data model adaptation (Figure 7).

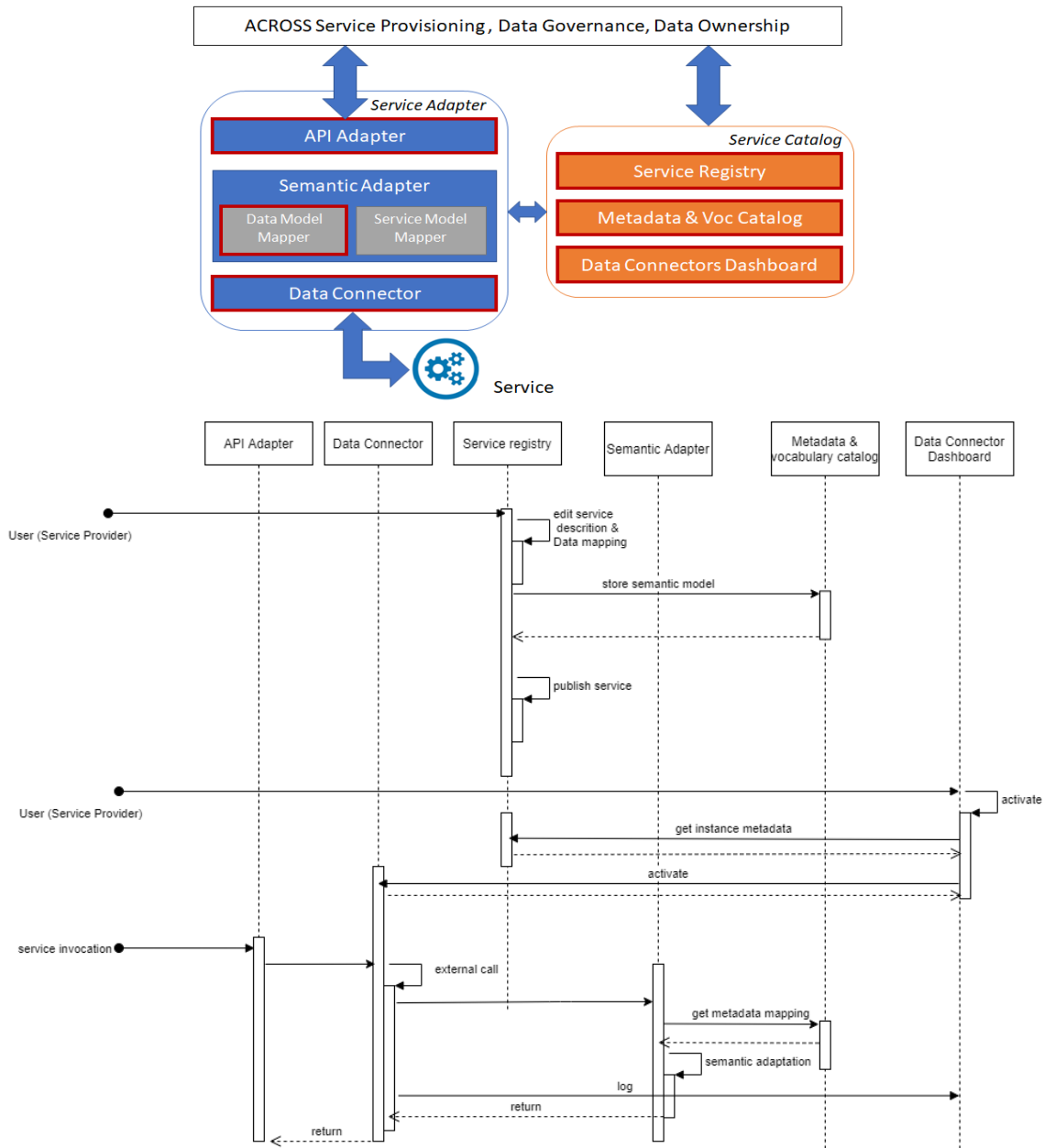

Figure 7 - Modules involved (and related flow) in Service invocation adaptation

In general, as depicted in the following Figure 8, each module interacts or it is invoked in order to provide a specific functionality or a piece of information, to be used also externally to ACROSS platform, for example to export service model description in a standard format.

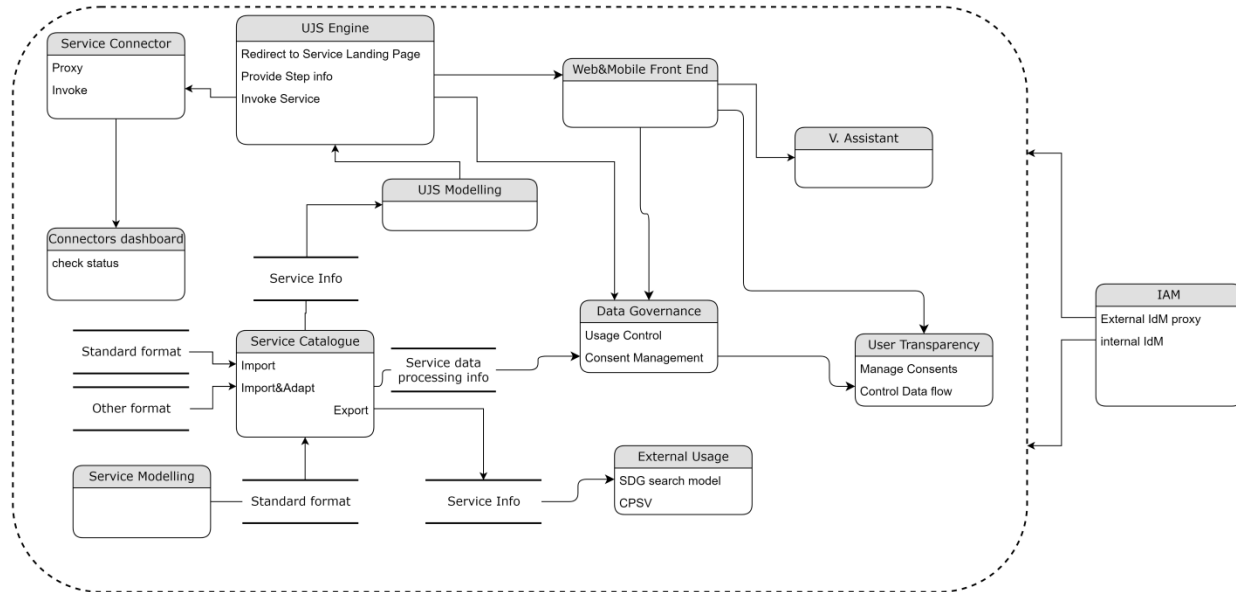

Figure 8 - Service Catalogue and Service Adapted modules interaction map with other modules of ACROSS platform.

2.2 Service Model

As described in the previous section, in order to support a uniform and harmonized machine-readable description of public and private services a service model has been defined to collect all information from the three point of view (Informational, Service invocation, Data Governance&Ownership) and managed in the Service Catalogue. The idea is to define this model by including and extending existing common models to describe each view (Figure 9).

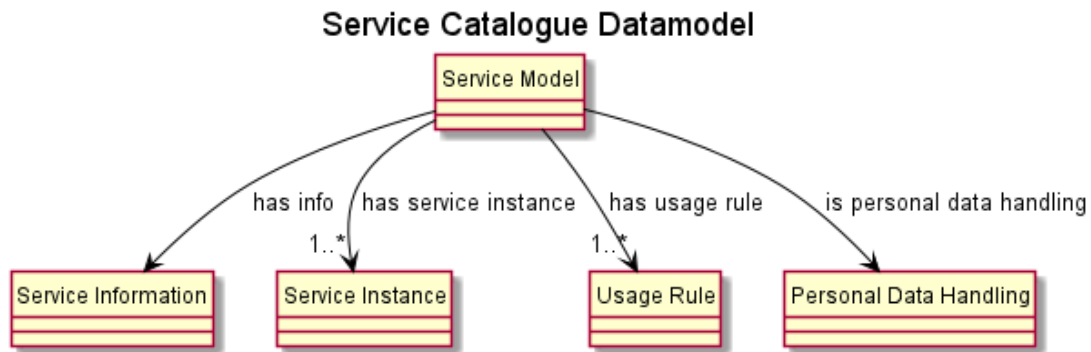

Figure 9 - Graphical representation of the Service Model main classes adopted in ACROSS



2.2.1 Information view

This section provides all information metadata of a service. This section follows the CPSV-AP, the Core Public Service Vocabulary Application Profile [2], a data model provided by the ISA2 Programme that is the result of a joint effort from different public administrations to reduce interoperability barriers. The CPSV-AP provides public administrations with a common data model for describing public services related to business and life events and to facilitate the set-up of catalogues of services oriented to businesses and citizens. With the CPSV-AP, public administrations can (i) provide information on public services in a user-centric way, grouped logically around business or life events and other ways of classifying; (ii) map different data models to a common model requiring only one single description and (iii) federate and publish information on Points of Single Contact and eGovernment portals in a more efficient and interoperable way.

The definition of CPSV-AP model has followed the main objective to provide a lightweight and modular standard that can be reused. The CPSV-AP specifies only 2 mandatory classes (Public Service and Public Organisation) (Figure 10) and the data model itself is based on other standards such as the Core Public Organisation⁴, the Core Criterion And Evidence⁵ and the ELI Vocabulary⁶.

The CPSV-AP enables the description of public services and the associated life and business events, by standardising the semantics of personal milestones, including having a child, beginning education, looking for a new job, as well as professional changes such as starting or financing a company, hiring an employee. The descriptions will make data on these events structured, easier to capture and machine-readable. Public administrations and service providers can use this to guarantee a degree of cross-domain and cross-border interoperability between public service catalogues. These aspects contribute to address ACROSS requirements (section 7) for a Semantic and technical interoperability with SDG (single digital gateway) in order to *“Easy and user-friendly access to information means enabling the users to easily find the information, to easily identify which parts of the information are relevant for their particular situation and to easily understand the relevant information”*[4] and to address the recommendation to *“...use the Core Public Services Vocabulary (CPSV) to facilitate interoperability with national service catalogues and*

⁴ <https://joinup.ec.europa.eu/collection/semantic-interoperability-community-semic/solution/core-public-organisation-vocabulary/about>

⁵ <https://joinup.ec.europa.eu/solution/core-criterion-and-core-evidence-vocabulary/about>

⁶ <https://publications.europa.eu/en/web/eu-vocabularies/model/-/resource/dataset/eli>

semantics. Member States should be encouraged to use the CPSV, but are free to decide to use national solutions. The information included in the repository for links should be made publicly available in open, commonly used and machine-readable format, for example by application programming interfaces (APIs), in order to enable its reuse.”

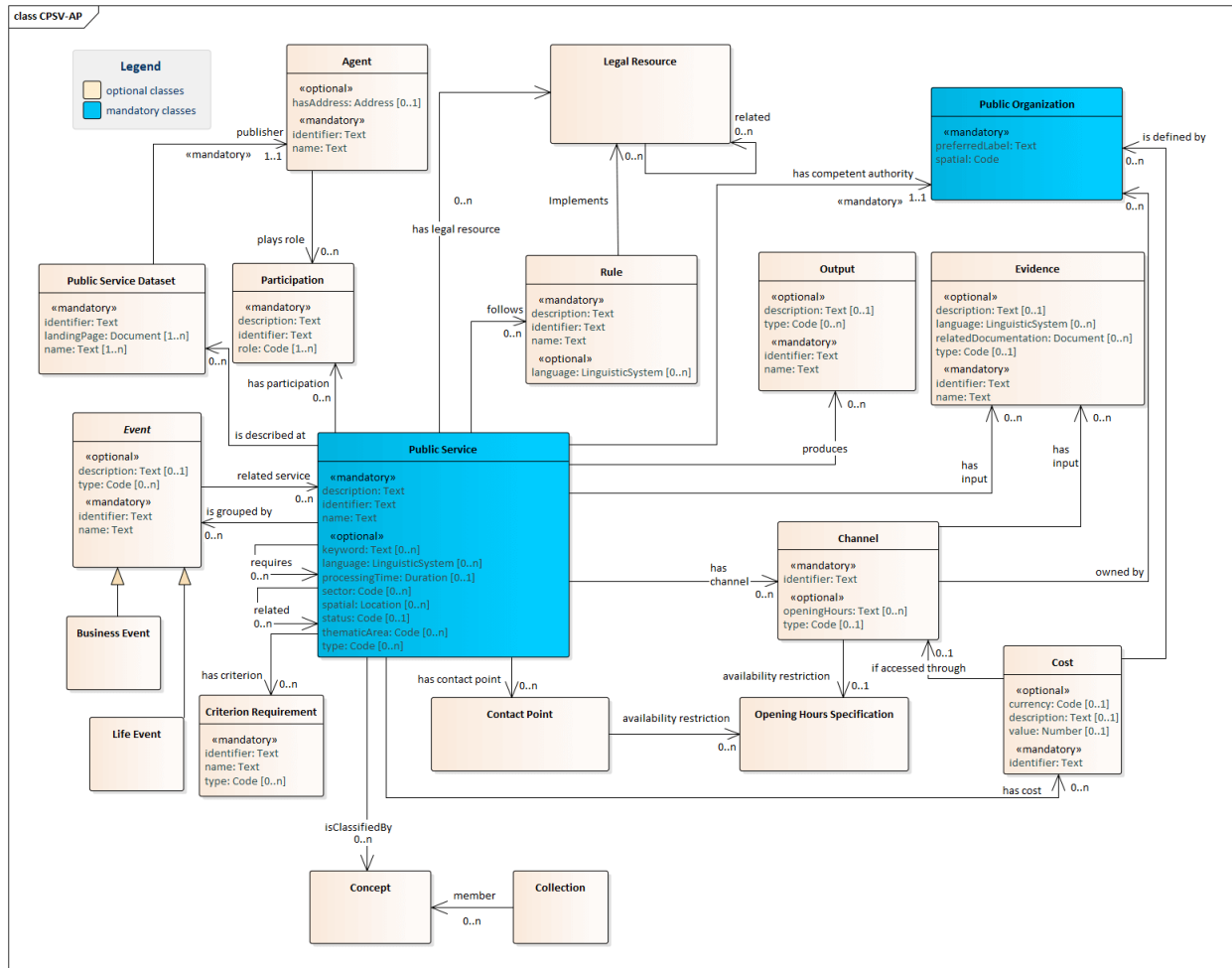

Figure 10 - Graphical representation of the relationships between the classes and properties of the full Core Public Service Vocabulary Application Profile (figure from [2])

In the context of Public Services, the CPSV-AP data model brings in the concepts of input (class Evidence) and output (actual result of executing a given Public Service) that might link to other Public Service's input and output. Furthermore, the CPSV-AP data model provides properties (such as “required” and “related”) which allow to explicitly indicate other required and/or related public services. This information will be used to support the user journey modelling and service engine (see Figure 8).

2.2.2 Usage Rule and Personal Data Handling views

Usage Rule and Personal Data Handling views capture information about for handling data access rights. In particular Usage Rule view provides an interoperable information model, vocabulary, and encoding mechanisms for representing statements about the usage of content and services. This model, as described in [3] is based on IDS Usage Control Model [8] a specialization of the Open Digital Rights Language (ODRL)⁷ to enforce usage restrictions for data, namely contract agreements, after access has been granted. Therefore, the purpose of usage control is to bind policies to data being exchanged and to continuously control the way how messages may be processed, aggregated, or forwarded to other endpoints. In the defined Service Model, a one-to-many relationship is defined (see section 5.8) mapping a service description with one or more contract agreements defined in a separated model and not stored and managed by the Service Catalogue but managed by the components of Data Ownership and Usage Control layer.

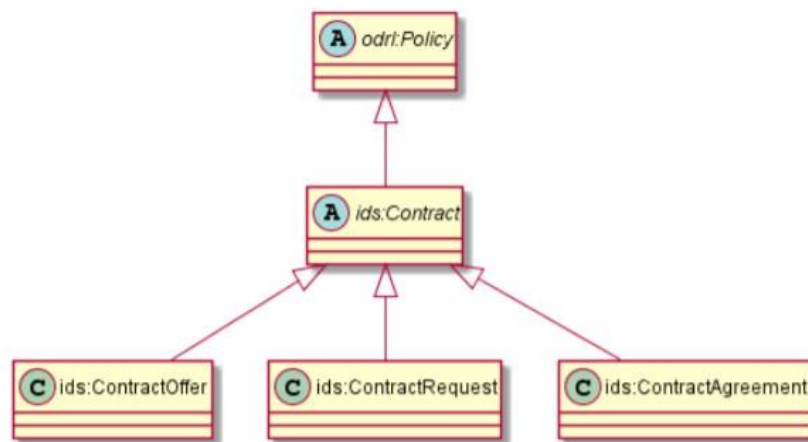

Figure 11 - IDS Contract Agreement

The personal Data Handling section is a specialized profile of The Data Privacy Vocabulary (DPV) [5] providing terms (classes and properties) to describe and represent information about personal data handling. In particular, the vocabulary provides extensible taxonomies of terms to describe the following components:

- Personal Data Categories
- Purposes
- Processing Categories

⁷ <https://www.w3.org/TR/odrl-model/>

- Technical and Organisational Measures
- Legal Basis such as Consent
- Entities such as Recipients, Data Controllers, Data Subjects
- Rights
- Risks

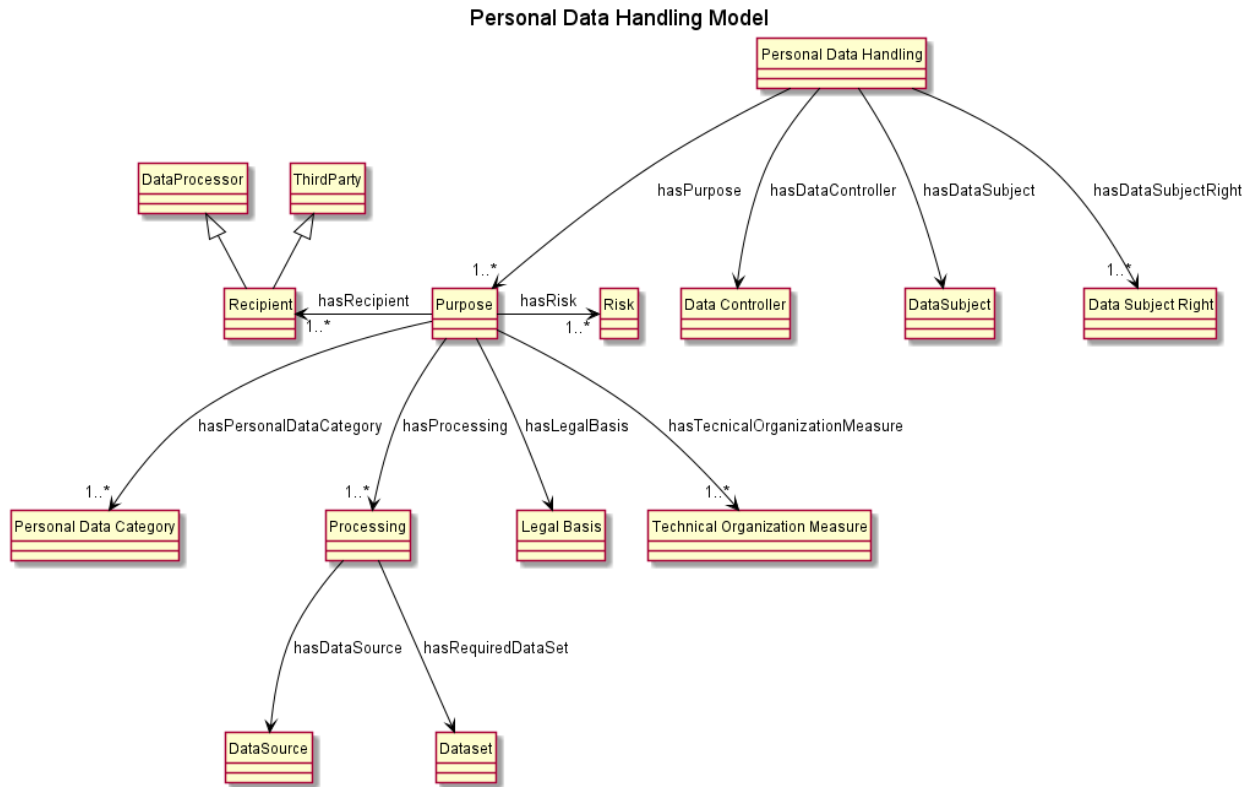

Figure 12 - Class diagram of Personal Data Handling model as profile of Data Privacy Vocabulary (DPV)

These terms are intended to represent personal data handling as machine-readable information by specifying personal data categories undergoing processing, its purpose(s), the data controller(s) involved, recipient(s) of this data, the legal bases or justifications used (e.g. consent or legitimate interest), involving technical and organisational measures and restrictions (e.g. storage location and storage duration), the applicable rights, and possibility of risks.

Examples of applications where the concepts provided by the DPV can be used are:

1. represent policies for personal data handling
2. represent information about consent e.g. provenance of consent



3. log/document personal data handling actions e.g. by a data controller
4. support automated checking of legal compliances of data handling ex ante (prior to processing), or ex post (i.e. check compliance after processing)

In accordance to the above application scenarios, the Personal Data Handling section uses the DPV vocabulary to collect all needed information that will be consumed by the Consent Manager component of Data Ownership and Usage Control layer (see [3]).

2.2.3 Service Instance view

This view provides all operational information to manage and invoke each service instance mediated by the related service adapter. It includes at least:

- Internal technical details to interact with internal components (e.g. data governance)
- Data/service connector invocation
- API Documentation (Open API/Swagger)
- Authentication and Authorization endpoints

The view will be extended with further information during the evolution of service adapter and all the components of ACROSS platform.

Detailed information about Service Model is provided in [Annex I](#).

2.3 Service Catalogue

The following sections provide an overview of the initial Service Catalogue implementation [6].

Service Catalogue provides all functionality to register, model, map and publish and manage all the information needed to support the uses of a service (public&private) according to the three points of view of Service Model described in the previous section:

- Informational
- Service Invocation
- Semantic interoperability & Personal Data Governance

The catalogue enables the storage and publishing of service by providing general, technical and data processing information based on standard models in particular based on CPSV-AP.

The Service Catalogue is a layered application implementing the Service Registry (front-end and backend) and Metadata Catalogue features, to provide APIs (see [Appendix II](#)) for programmatically interaction with other components of ACROSS platform and dashboards and

graphical editors supporting users to manage service descriptions and related model adaptation (Figure 13).

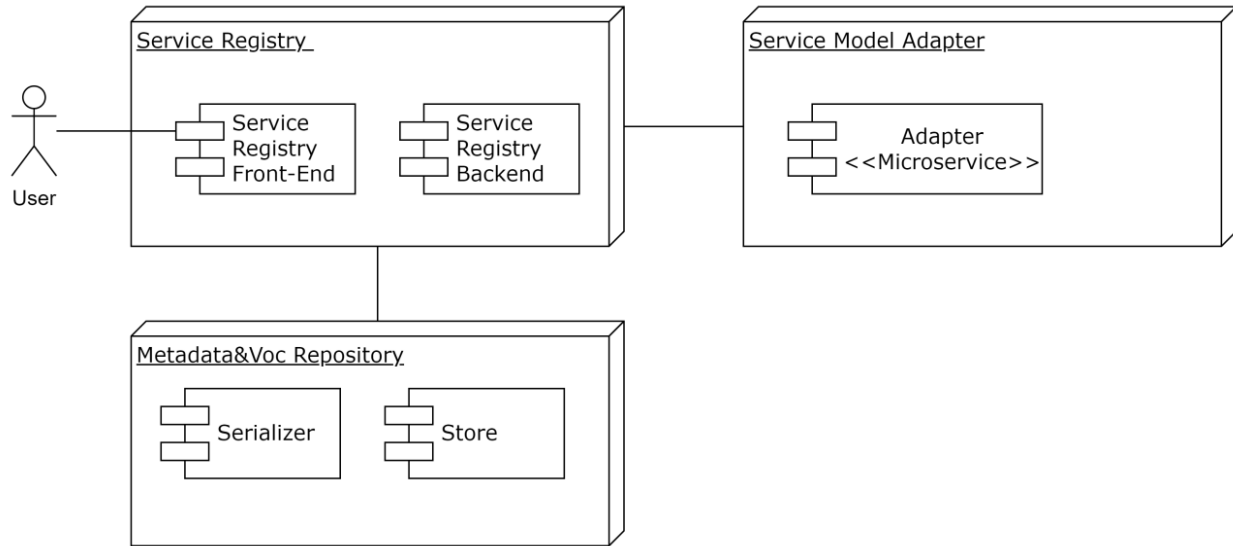

Figure 13 - Main modules implemented by the Service Catalogue

The Backend is implemented as Spring Boot⁸ Java microservice, and will be deployed with a tightly coupled storage service (MongoDB⁹ 4.2+). The Front-end, is an Angular portal based on Nebular¹⁰ framework (Figure 14).

⁸ <https://spring.io/projects/spring-boot>

⁹ <https://www.mongodb.com/>

¹⁰ <https://akveo.github.io/nebular/>

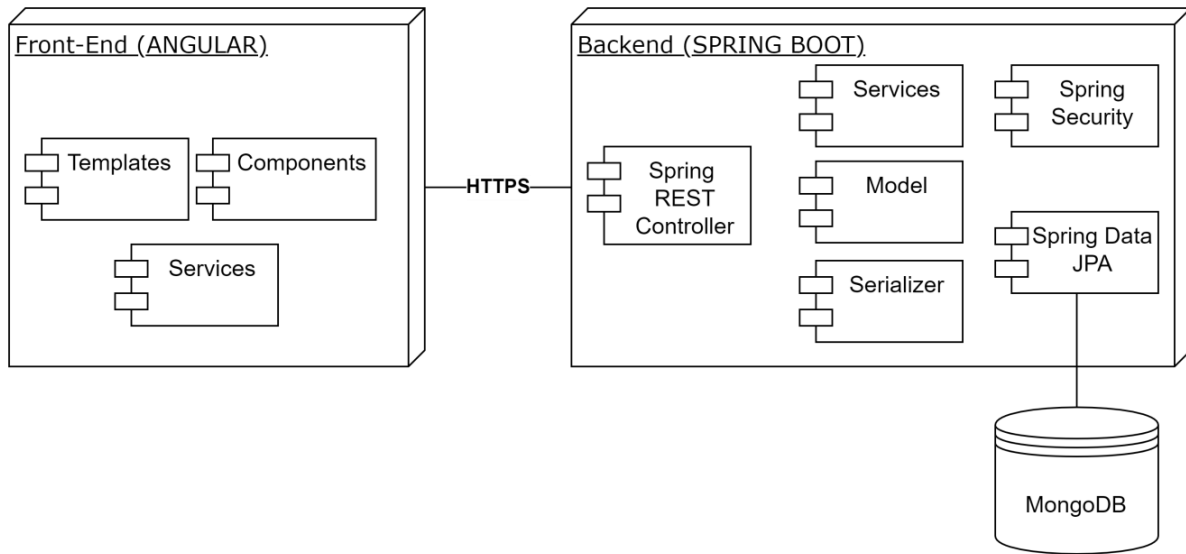

Figure 14 - Front-End and Backend of Service Catalogue implementation

The two layers can be deployed as Docker¹¹ containers, based on Tomcat Alpine image¹² and paired with a MongoDB container. This adoption of several reliable and production ready technologies (Figure 15) guarantees robustness and modularity of the solution.



Figure 15 - Adopted technologies in Service Catalogue implementation

¹¹ <https://www.docker.com/>

¹² https://hub.docker.com/_/tomcat

Service Catalogue architecture implementation is completed by integrating Spring Security and Keycloak¹³ that supports OpenId Connect¹⁴ and OAuth2¹⁵ authorization framework. The Service Catalogue uses the Open Id Connect protocol upon the OAuth2 Authorization workflows, in order to perform User authentication and obtain an Access Token (JWT), which will be used to grant access. Similarly, a client application/service wanting to interact with the Service Catalogue, will perform OAuth2 Authorization, obtaining an Access Token to be used in the request to APIs (Figure 16).

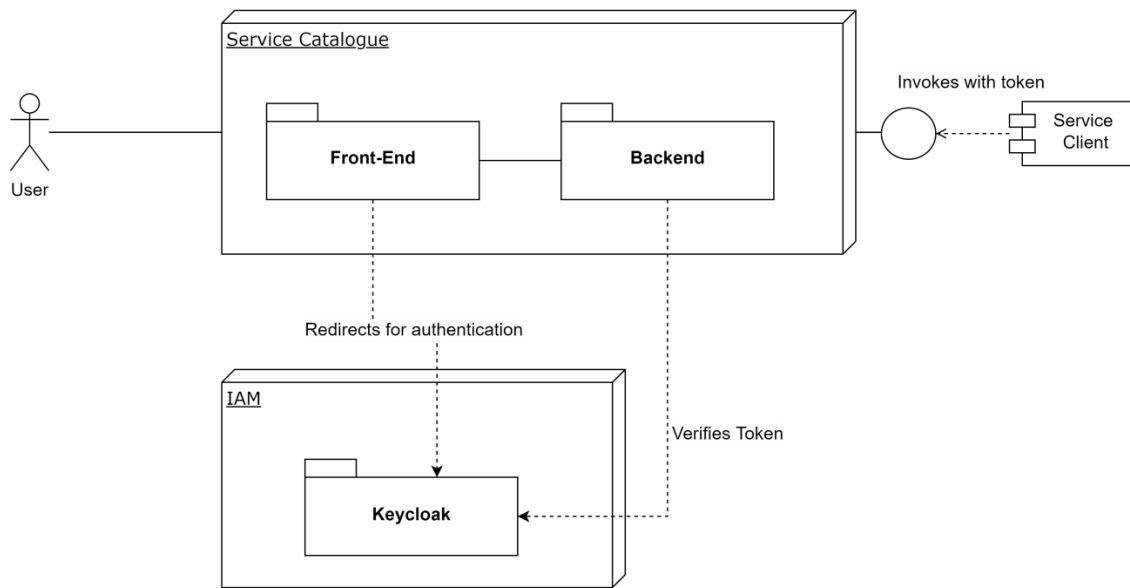

Figure 16 - Interaction of Service Catalogue with Keycloak for identity and access management

¹³ <https://www.keycloak.org/>

¹⁴ <https://openid.net/connect/>

¹⁵ <https://oauth.net/2/>

The choice of Keycloak provides an out of box solution for a rapid security layer development of application with supporting features such as Single-Sign-On (SSO), Social Login, User Federation, Client Adapters, Admin Console and Account Management Console and finally Identity Brokering¹⁶ (Figure 16). This last aspect will facilitate the integration of the Service Catalogue with multiple and specific identity Systems.

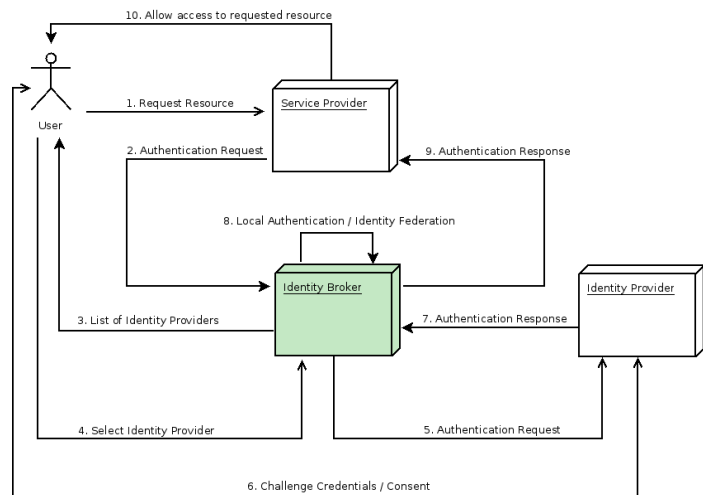

Figure 17 - Identity brokering flow supported by Keycloak

2.3.1 Service Manager

The Service Manager is a multi-role Angular¹⁷ based admin dashboard implemented with the aim to include all module sections to interact with Service Catalogue but at the time, according to the role of authenticated user to manage the consents registry as Data Controller. By following this implementation approach the Angular based Service Manager could enable further module extensions, each dedicated to a single purpose (Figure 18).

¹⁶ https://www.keycloak.org/docs/latest/server_admin/#_identity_broker

¹⁷ <https://angular.io/>

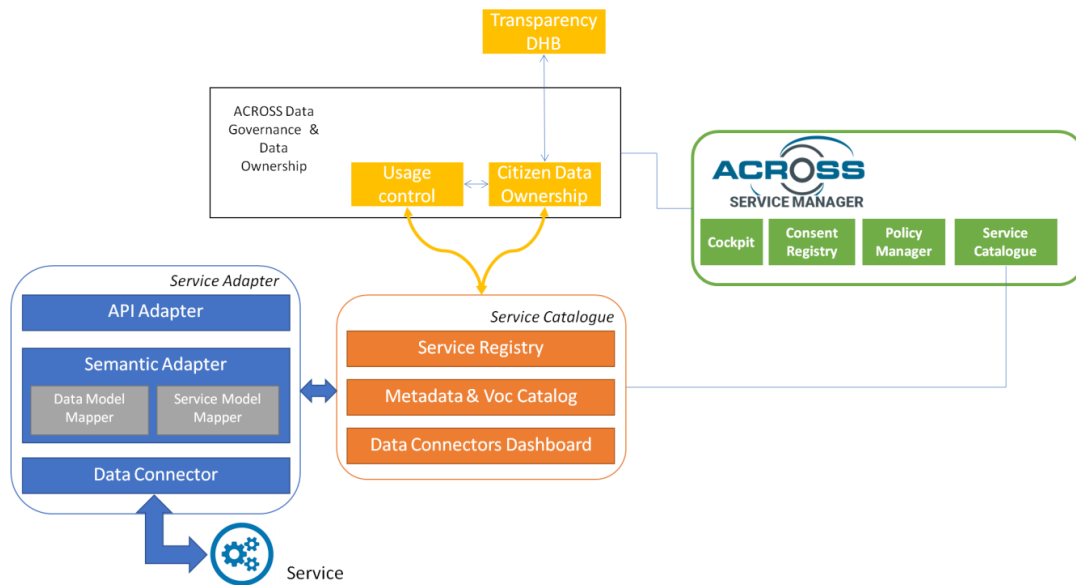

Figure 18 - The Service Manager admin dashboard provides a modular web interface to interact with several layers of ACROSS Platform.

The Service Manager uses Keycloak as identity broker providing at login phase an extensible page to select optional authentication systems (Figure 19).

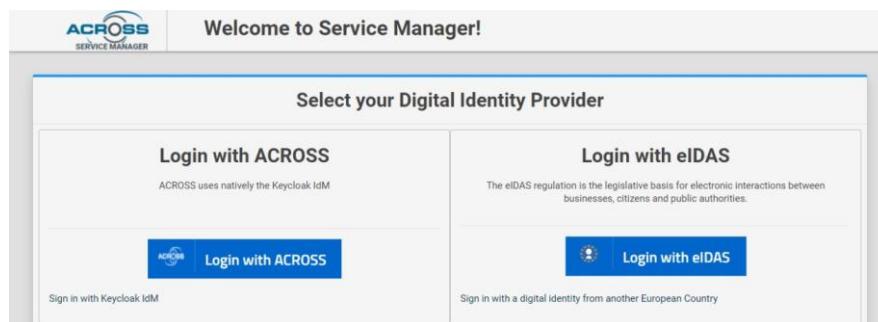

Figure 19 - Authentication page of Service Manager

In particular for eIDAS authentication, or national identity schemes, a dedicated adapter should be implemented, brokered by Keycloak.

Once authenticated, the user according to the roles assigned by means of Keycloak¹⁸ the user can access to several sections. In particular can view the list of already inserted services by having a first look about their basic information (name, status, description...), or to be redirected to the "detail" page (Figure 20).

¹⁸ https://www.keycloak.org/docs/latest/server_admin/

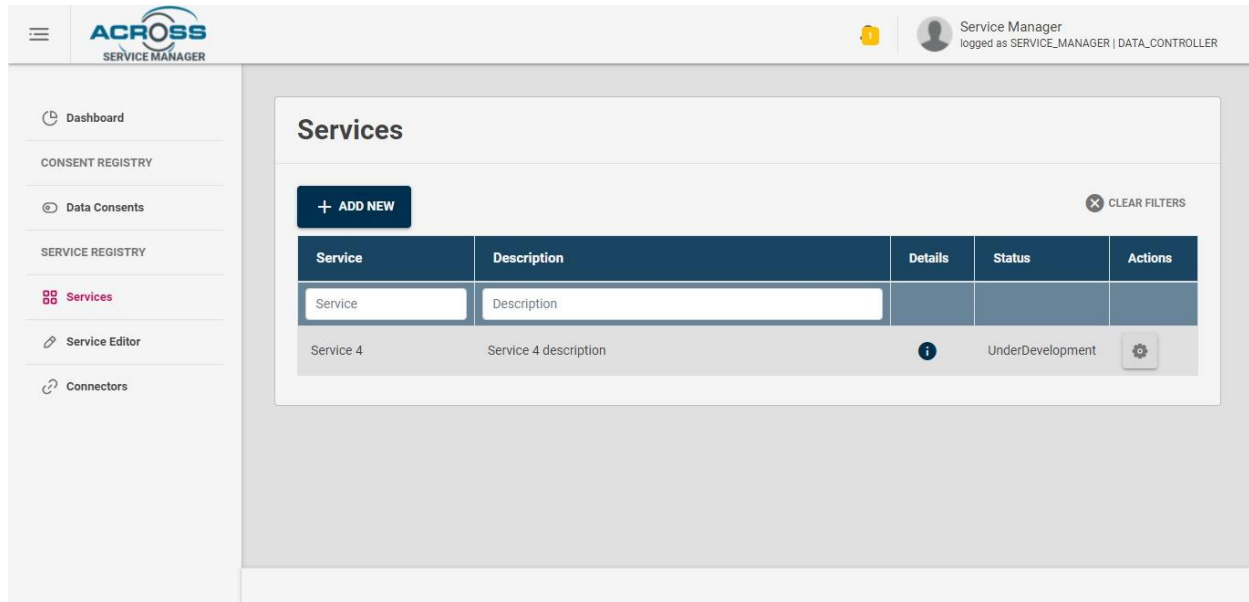

Figure 20 - Service list page

From "Actions" the user can perform several actions in accordance to the status of service (Figure 21):

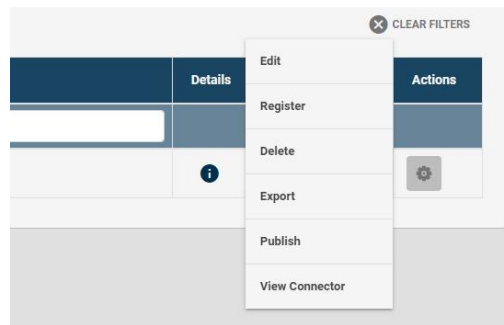

Figure 21 - Available actions in accordance to the status of service

- *Edit*. User can modify or complete service description, by entering in edit mode page
- *Register*. This action changes the status of service description into "completed". Once completed the service is searchable, by means of APIs exposed by the Service Catalogue, by ACROSS components.
- *Delete*. User can delete a service description. The action can be performed if the service is in the status of "UnderDevelopment" or after a de-registration.

- *Export*. User can export the description of Service by selecting different formats (Figure 22): JSON, JSON-LD, CPSV-AP Model (json-ld) and Single Digital Gateway Search Service model¹⁹ (not already completed)
- *Publish*. Not yet implemented. It lets to publish externally the service description at all or some information.
- *View Connector*. Not yet implemented. It lets to switch to the related connector adapter page.

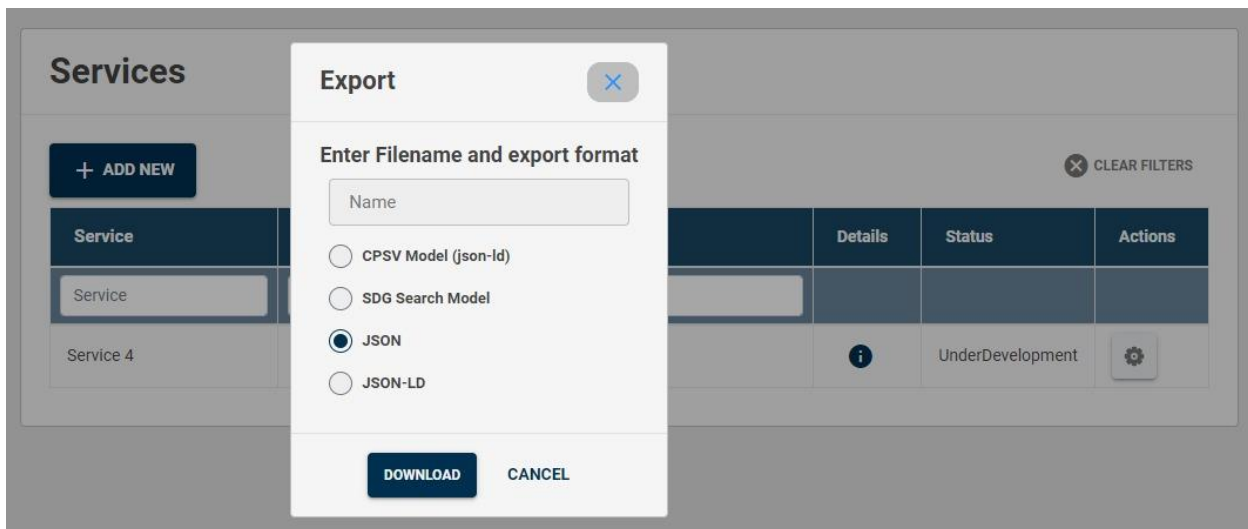

Figure 22 - Export dialog

From the list page the user can add a new service description by clicking on "Add new" button. The user is redirected to Service Editor page. It is composed in several tabs in relation to the Service model views described in section 2.2 and detailed in [Annex I](#)

¹⁹ <https://github.com/catalogue-of-services-isa/SDG-search-service-model>

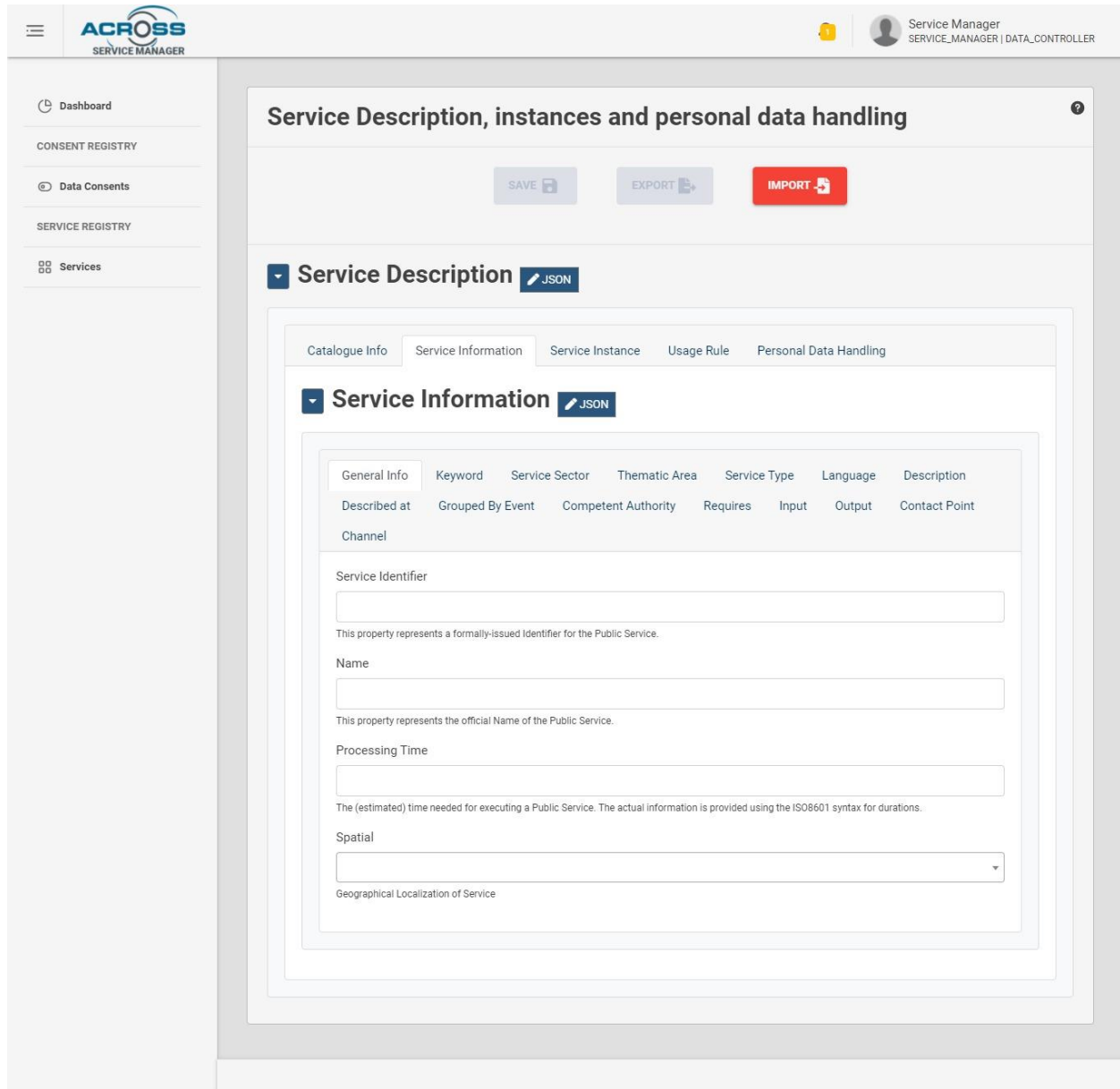

Figure 23 - Service Editor page

Each property is documented with a description and by clicking the "?" button in the in the top right-hand corner a guide is provided. The user can import existing standard service models or non-standard/legacy descriptions by selecting the suitable registered service model adapter(Figure 24).

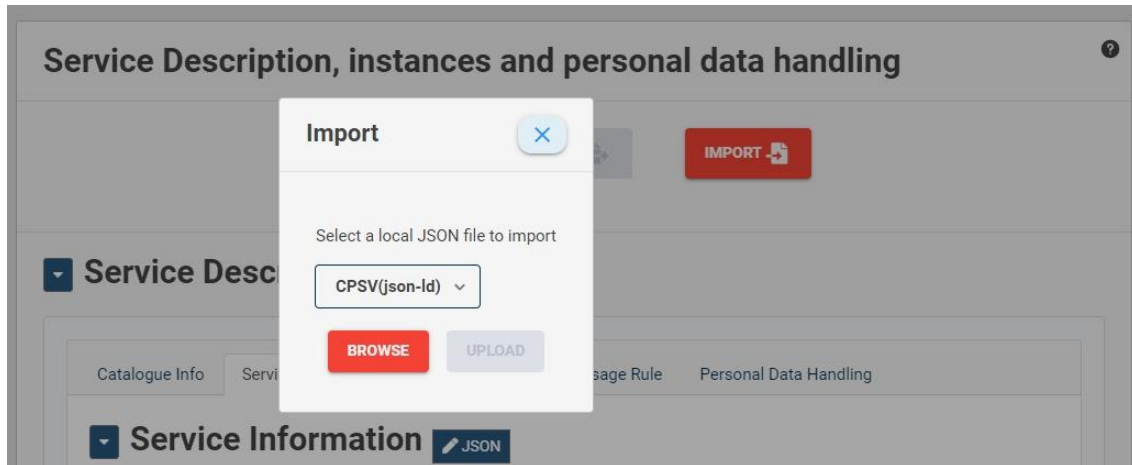

Figure 24 - Import dialog

The "Connectors" section (Figure 25) will provide quick information about the registered connectors and their status and logs.

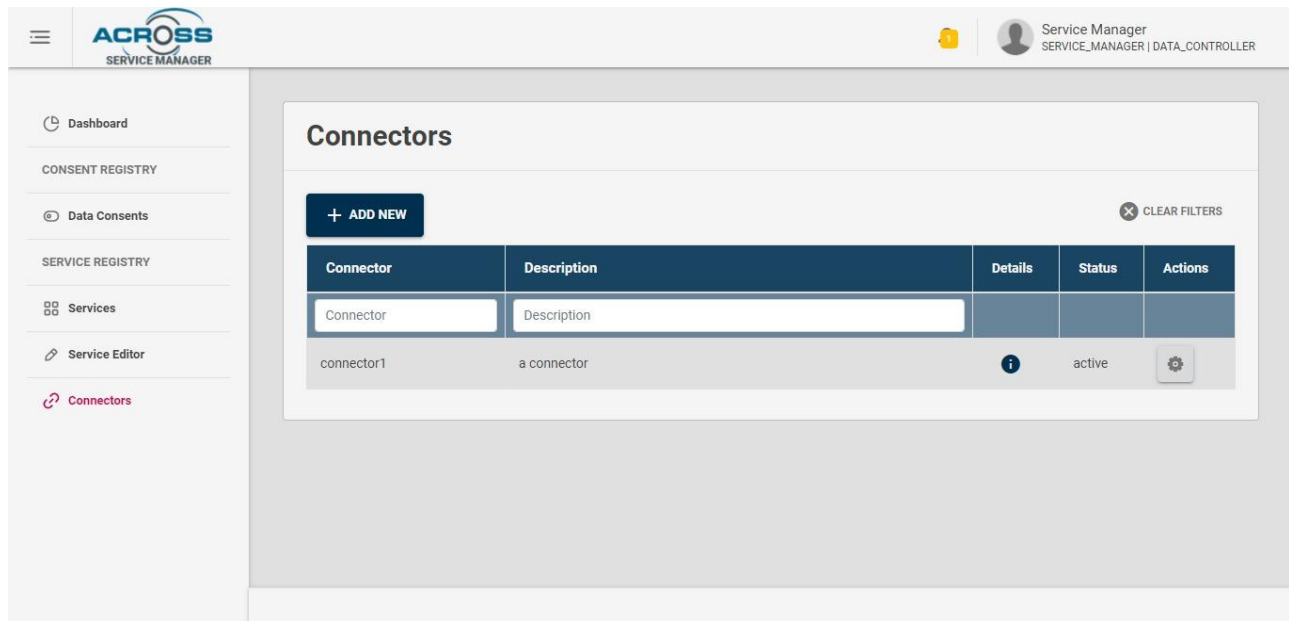

Figure 25 - Connectors list page

The "Data Consents" page provides, if the authenticated user has "data-controller" role, a registry of consents collected. It is a front-end client of the APIs provided by the Consent Manager component of Data Governance & Data Ownership layer of ACROSS platform.

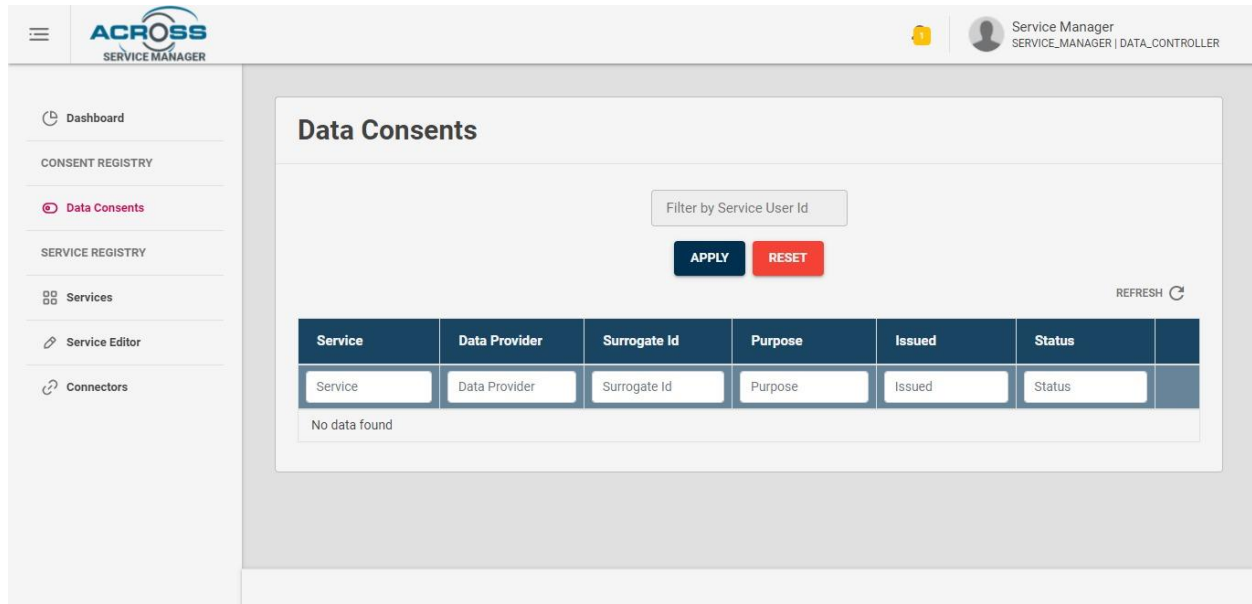

Figure 26 - Consent Registry page

Finally, the section "Dashboards" provides an extensible page of graphical dashboard cards providing some summaries about the inserted services (Figure 27).

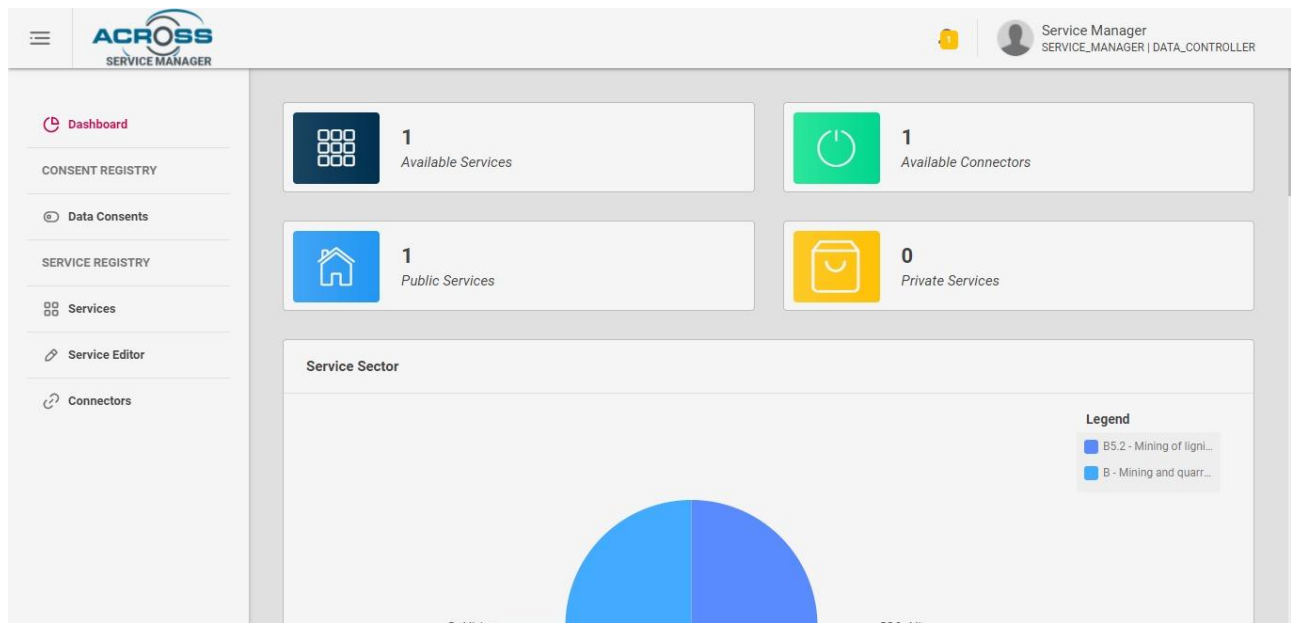

Figure 27 - Dashboard page



2.4 Service Adapter and baseline technologies

As defined in section 2 Service adapters are single instances of adaptation of services (public & private) for its use in ACROSS Platform useful to adapt heterogeneous service definitions into a common one and encapsulate generic communications-related logic required to use services and also to include logic that is quite specific for a given service. In particular connectors components make resources like database tables, stored procedures, domain objects, or files accessible to clients with a minimal amount of coding.

In the following section a preliminary description of technologies that will be leveraged and extended to implement the common part skeleton of a Service Adapter.

2.4.1 Data Model Mapper

The Data Model Mapper tool²⁰ enables to convert several file types (e.g. CSV, Json) to different defined data models. The files in input can contain either rows, JSON objects or other structured data, each of them representing an object to be mapped to an entity, according to the selected Data Model.

In particular, it performs following steps:

1. *Parsing:*
 - Parse input file, by converting it into a row/object stream.
 2. *Streaming:*
 - Each row/object coming from the stream is converted to an intermediate object.
 3. *Mapping:*
 - By using the input JSON Map, convert the intermediate object to an entity, according to a specific target Data Model.
 4. *Validation and report:*
 - Validate resulting object against the JSON schema corresponding to a target Data Model.
 - Produce a report file with validated and unvalidated objects.
- *Writing: Context broker or File*
 - Validated objects can be sent to a configured context broker to the configured context broker²¹ and/or to a local file.

²⁰ <https://gitlab.com/synchronicity-iot/data-model-mapper>

²¹ <https://ec.europa.eu/cefdigital/wiki/display/CEFDIGITAL/Context+Broker>

The tool is developed in Node.js²² and can be started as a command line tool. The current implementation is going to be extended to implement the Semantic Adapter as microservice module to be further customized for the specific service/data model adaptation.

2.4.2 IDS Data Connector

In International Data Spaces (IDS) Reference Architecture Model (RAM)[9], the Connector is one of main technological building blocks. It is a dedicated software component allowing a Consumer and a provider to exchange, share and process digital content. At the same time, the Connector ensures that the data sovereignty of the Data Owner is always guaranteed.

It is a configurable component, providing several system services enabling secure bidirectional communication, enforcement of content usage policies, system monitoring, and logging of content transactions for clearing purposes. The functional range of a generic Connector may be extended by custom software (Data Apps), allowing data processing, visualization, persistence, etc. The Connector provides metadata to the Data Consumer Connector as specified in the Connector's self-description. For example, technical interface description, authentication mechanism, exposed data sources, and associated data usage. Following the peer-to-peer network concept, the data is transferred between the Connectors of the Data Provider and the Data Consumer (Figure 28).

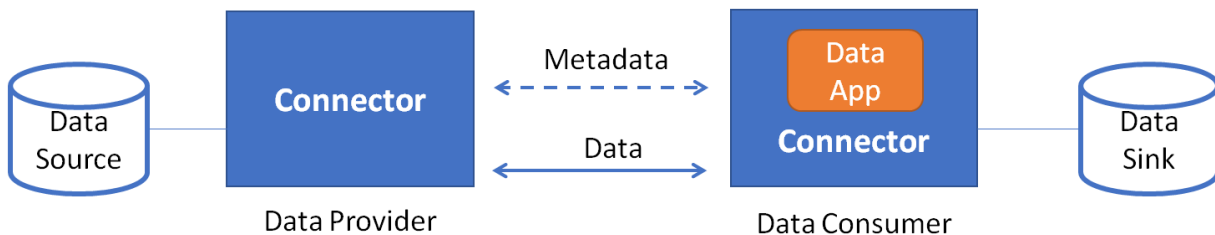

Figure 28 - IDS connector interactions

In the implementation of Service Adapter the open-source IDS connector TRUE (TRUsted Engineering) Connector²³ (Figure 29) will be leveraged in order to fit the specific Service Adapter needs. In particular the trivial Data APP application in order to adapt data on top of the Execution Core Container.

²² <https://nodejs.org/>

²³ <https://github.com/Engineering-Research-and-Development/true-connector>

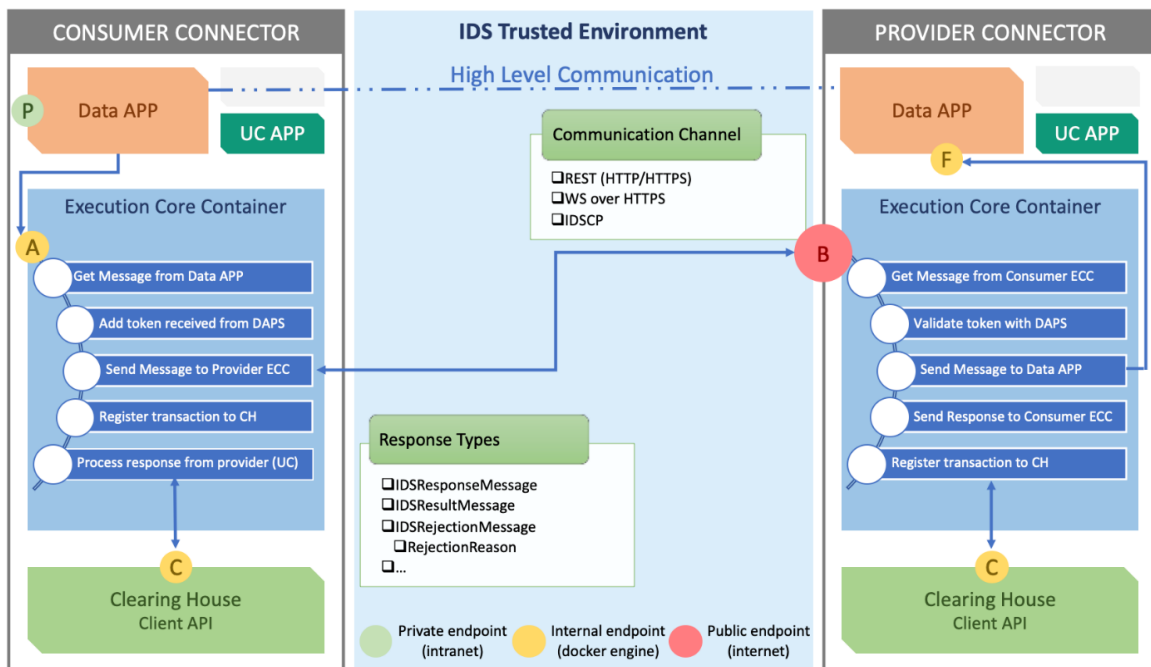

Figure 29 - TRUE Connector Architecture and Interactions

Considering the flows of interactions, the scenario depicted in Figure 29 shows how the Consumer connector accesses data from the Provider connector. Specifically, the Consumer connector receives a request to its P endpoint, it forwards the request to its internal Execution Core Container (A endpoint) which is in charge of establishing a secure communication with the Provider Execution Core Container to access the data. The Consumer's ECC receives the message from its Data APP, interacts with an external Identity Provider to retrieve the token of the Consumer and send the appropriate IDS message to the Provider's ECC using one of the provided communication channels (B endpoint). The Provider's ECC receives the message and validates the token against the Identity provider, then it retrieves the actual data from its Data APP (F endpoint), and returns it to the Consumer's ECC who, finally, processes the response, applies the usage control policies and forward the data to the original requester. All the transactions are logged into the Clearing House (C endpoints).

As introduced in [3] in ACROSS platform usage policy enforcement capabilities will be provided externally to IDS connector in Usage Control component in the Data Governance & Data Ownership layer of ACROSS platform.



3 Conclusions and next steps

This report has documented the result of activities performed in Task 4.2 " Public & Private sector offerings management tool" taking into account the relations with the other activities involved in the definition and implementation of ACROSS Platform and related components. The report described the architecture of Data harmonization and connectors layer to support service adaptation and how each component is involved in the flow of according to the type of adaptation performed. The main focus of this report is describing the initial release of Service Catalogue components and the detailed definition of the related service model.

The service model has the goal to collect the multi-view of information of a service to be used in ACROSS Platform for the delivery of a user journey service. This model will evolve accordingly to the evolution of ACROSS Platform component, taking into account internal and external feedback and new requirements. This evolution will contribute into the continuous evolution of Service Catalogue functionality and its internal model. The layered implementation of Service Catalogue and the adopted technologies allow the service model evolution with a minimal amount of effort.

At the same time, we will proceed with the detailed definition and implementation of the core components of the service adapter, taking into account the baseline technologies described in this report.



4 References

- [1] ACROSS, D5.1 - System Architecture & Implementation Plan – Initial
- [2] D02.02 – Core Public Service Vocabulary Application Profile 2.2.1 ([https://joinup.ec.europa.eu/rdf_entity/http e f fdata ceuropa ceu fw21 fafebf2ed-4717-4f8a-b7d6-270f00743324](https://joinup.ec.europa.eu/rdf_entity/http%20ef%20data%20europa%20eu%20fw21%20fafebf2ed-4717-4f8a-b7d6-270f00743324))
- [3] ACROSS, D3.1 - Design of the ACROSS Data Governance framework for data sovereignty – Initial
- [4] Regulation (EU) 2018/1724 of the European Parliament and of the Council of 2 October 2018 establishing a single digital gateway to provide access to information, to procedures and to assistance and problem-solving services and amending Regulation (EU) No 1024/2012 (<https://eur-lex.europa.eu/eli/reg/2018/1724/oj>)
- [5] Data Privacy Vocabulary (DPV) <https://dpvcg.github.io/dpv/>
- [6] Service Catalogue source code: <https://github.com/OPSILab/Service-Catalogue>
- [7] APIs for CPSV-AP based Catalogue of Services:
[https://joinup.ec.europa.eu/sites/default/files/news/2019-09/ISA2 APIs%20for%20CPSV-AP%20based%20Catalogue%20of%20Services.pdf](https://joinup.ec.europa.eu/sites/default/files/news/2019-09/ISA2_APIs%20for%20CPSV-AP%20based%20Catalogue%20of%20Services.pdf)
- [8] Usage Control in IDS https://internationaldataspaces.org/wp-content/uploads/dlm_uploads/IDSA-Position-Paper-Usage-Control-in-the-IDS-V3..pdf
- [9] IDS Reference architecture Model v3 - <https://internationaldataspaces.org/wp-content/uploads/IDS-Reference-Architecture-Model-3.0-2019.pdf>



5 Annex I - ACROSS Service Model

The following sections provides a deeper description of the ACROSS Service Model.



5.1 Service Model class diagram

The following Figure 30 provides the complete class diagram structure of Service Model adopted in Service Catalogue. Each class in the class diagram is described in the following sections

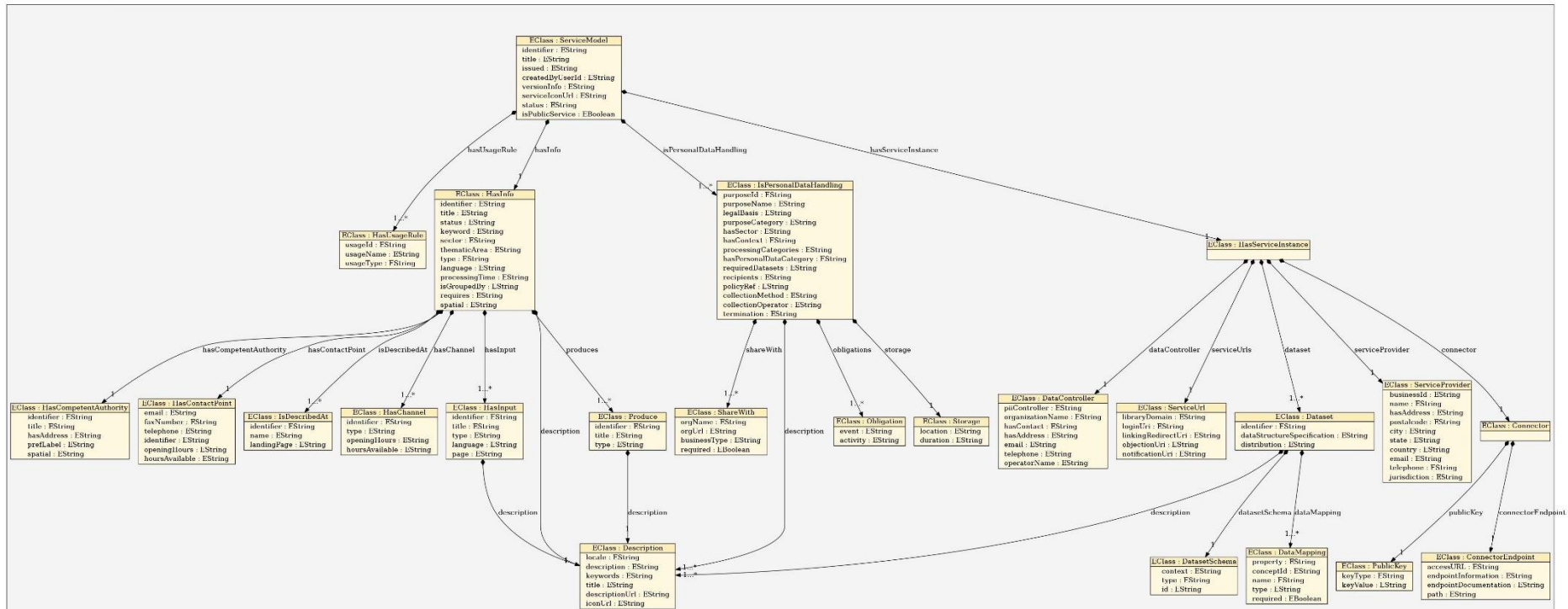

Figure 30 - Complete class diagram of Service Model

5.2 Service Basic Info

Each service to be registered in the Service Catalogue has to provide some basic information.

Table 1 Basic Info properties of Service Model class

Property	Type	Description
title	String (1..1)	Service Name
identifier	String (1..1)	Id of service or service URI if exists. This identifier will be used by the Service Catalogue to identify it and could be the same identifier provided in the information section 5.3.
issued	String (0..1)	When Service entry was created (system log data)
createdByUserId	String (0..1)	User Id (if any) of Service Editor
serviceDescriptionVersion	String (0..1)	Service description version number
serviceIconUrl	String (0..1)	URL pointing to service's icon (if available)
status	String (0..1)	Status of Service ["Completed", "Deprecated", "UnderDevelopment", "Withdrawn"]
isPublicService	Boolean (1..1)	If service is public or not
hasInfo	Object (1..1)	Object describing Service information section. See 5.3
hasServiceInstance	Object (1..1)	Object describing Service information section. See 5.4
isPersonalDataHandling	Object (1..n)	Object describing Personal data handling. See 5.7
hasUsageRule	Object (1..n)	Object describing Service usage Rules. See 5.8

5.3 Service Information section

Each service should provide basic information, identification, service classifications and locale descriptions. Such classifications are only related to public services, according to ISA² Core Public Service Vocabulary Application Profile (CPSV-AP). The following classes and properties belong to ISA² CPSV-AP v2.2.1 [2], and here are reported for completeness of this report.

Table 2 - Service Information Class

Property	Type	Description									
Name	String (1..1)	It represents the official Name of the Public Service									
Identifier	String (1..1)	This property represents a formally-issued Identifier for the Public Service.									
Description	Object (1..1)	This property represents a free text Description of the Public Service. The description is likely to be the text that potential users of the Public Service see in any public service catalogue.									
		<table border="1"> <thead> <tr> <th><i>Property</i></th> <th><i>Type</i></th> <th><i>Description</i></th> </tr> </thead> <tbody> <tr> <td>locale</td> <td>string</td> <td>Language used in information, ISO 639-1 coded</td> </tr> <tr> <td>description</td> <td>string</td> <td>Textual description</td> </tr> </tbody> </table>	<i>Property</i>	<i>Type</i>	<i>Description</i>	locale	string	Language used in information, ISO 639-1 coded	description	string	Textual description
		<i>Property</i>	<i>Type</i>	<i>Description</i>							
		locale	string	Language used in information, ISO 639-1 coded							
description	string	Textual description									
Keyword	String (0..n)	This property represents a keyword, term or phrase to describe the Public Service.									
Sector	String (0..n)	This property represents the industry or sector a Public Service relates to, or is intended for. For example: environment, safety, housing. Note that a single Public Service may relate to multiple sectors. The possible values for this property are provided as a controlled vocabulary. See section 4 in [2].									
Thematic Area	String (0..n)	This property represents the Thematic Area of a Public Service as described in a controlled vocabulary, for instance social protection, health, recreation, culture and religion, family, travelling economic									



		affairs, tax, staff, environment. The recommended controlled vocabularies are listed in section 4 in [2].												
Type	String (0..n)	This property represents the Type of a Public Service as described in a controlled vocabulary. For the indicating the Type, we are referring to the functions of government to indicate the purpose of a government activity, which the public service is intended for. The recommended controlled vocabularies are listed in section 4 in [2].												
Language	String (0..n)	This property represents the language(s) in which the Public Service is available. This could be one language or multiple languages, for instance in countries with more than one official language. The possible values for this property are described in a controlled vocabulary. The recommended controlled vocabularies are listed in section 4 in [2].												
Status	String (0..1)	Indicates whether a Public Service is active, inactive, under development etc. according to a controlled vocabulary.												
Is Grouped By	String (0..1)	This property links the Public Service to the Event class (section 3.2.25 in [2]). Several Public Services may be associated with a particular Event and, likewise, the same Public Service may be associated with several different Events.												
Requires	String (0..n)	One Public Service may require, or in some way make use of, the output of one or several other Public Services. In this case, for a Public Service to be executed, another Public Service must be executed beforehand.												
Has Competent Authority	Object (1..1)	This property links a Public Service to a Public Organization, which is the responsible Agent for the delivery of the Public Service. Whether the particular Public Organization provides the public service directly or outsources it is not relevant. The Public Organization that is the Competent Authority of the service is the one that is ultimately responsible for managing and providing the public service. The CPSV-AP reuses the Core Public Organisation Vocabulary that defines the concept of a Public Organization and associated properties and relationships.												
<table border="1"> <thead> <tr> <th><i>Property</i></th> <th><i>Type</i></th> <th><i>Description</i></th> </tr> </thead> <tbody> <tr> <td>identifier</td> <td>String</td> <td>Public Organization identifier</td> </tr> <tr> <td>title</td> <td>String</td> <td>Name of Public Organization</td> </tr> <tr> <td>hasAddress</td> <td>String</td> <td>Address</td> </tr> </tbody> </table>			<i>Property</i>	<i>Type</i>	<i>Description</i>	identifier	String	Public Organization identifier	title	String	Name of Public Organization	hasAddress	String	Address
<i>Property</i>	<i>Type</i>	<i>Description</i>												
identifier	String	Public Organization identifier												
title	String	Name of Public Organization												
hasAddress	String	Address												



		<table border="1"> <tr> <td>prefLabel</td> <td>String</td> <td>Preferred Label</td> </tr> <tr> <td>spatial</td> <td>String</td> <td>Localization</td> </tr> </table>	prefLabel	String	Preferred Label	spatial	String	Localization												
prefLabel	String	Preferred Label																		
spatial	String	Localization																		
Has Input	Object (0..n)	<p>The Has Input property links a Public Service to one or more instances of the Evidence class (see section 3.9 in [2]). A specific Public Service may require the presence of certain pieces of Evidence in order to be delivered.</p> <table border="1"> <thead> <tr> <th><i>Property</i></th> <th><i>Type</i></th> <th><i>Description</i></th> </tr> </thead> <tbody> <tr> <td>identifier</td> <td>String</td> <td>Identifier (URI if available)</td> </tr> <tr> <td>title</td> <td>String</td> <td>Assigned Name</td> </tr> <tr> <td>type</td> <td>String</td> <td>Category of input</td> </tr> <tr> <td>language</td> <td>String</td> <td>Preferred Label</td> </tr> <tr> <td>page</td> <td>String</td> <td>Localization</td> </tr> </tbody> </table>	<i>Property</i>	<i>Type</i>	<i>Description</i>	identifier	String	Identifier (URI if available)	title	String	Assigned Name	type	String	Category of input	language	String	Preferred Label	page	String	Localization
<i>Property</i>	<i>Type</i>	<i>Description</i>																		
identifier	String	Identifier (URI if available)																		
title	String	Assigned Name																		
type	String	Category of input																		
language	String	Preferred Label																		
page	String	Localization																		
Produces	Object (0..n)	<p>The Produces property links a Public Service to one or more instances of the Output class (see section 3.10 in [2]), describing the actual result of executing a given Public Service. Outputs can be any resource, for instance a document, artefact or anything else being produced as a result of executing the Public Service</p> <table border="1"> <thead> <tr> <th><i>Property</i></th> <th><i>Type</i></th> <th><i>Description</i></th> </tr> </thead> <tbody> <tr> <td>identifier</td> <td>String</td> <td>Identifier (URI if available)</td> </tr> <tr> <td>title</td> <td>String</td> <td>Assigned Name</td> </tr> <tr> <td>type</td> <td>String</td> <td>Category of output</td> </tr> </tbody> </table>	<i>Property</i>	<i>Type</i>	<i>Description</i>	identifier	String	Identifier (URI if available)	title	String	Assigned Name	type	String	Category of output						
<i>Property</i>	<i>Type</i>	<i>Description</i>																		
identifier	String	Identifier (URI if available)																		
title	String	Assigned Name																		
type	String	Category of output																		
Spatial	String (0..n)	<p>The area covered. The possible values for this property are described in a controlled vocabulary. The recommended controlled vocabularies are listed in section 4 in [2].</p>																		



<p>Has Contact Point</p>	<p>Object (0..n)</p>	<p>The value of this property, the contact information itself, should be provided using schema:ContactPoint. Note that the contact information should be relevant to the Public Service which may not be the same as contact information for the Competent Authority or any Participant.</p> <table border="1" data-bbox="488 432 1414 1108"> <thead> <tr> <th><i>Property</i></th> <th><i>Type</i></th> <th><i>Description</i></th> </tr> </thead> <tbody> <tr> <td>email</td> <td>String</td> <td>Email</td> </tr> <tr> <td>faxNumber</td> <td>String</td> <td>Fax</td> </tr> <tr> <td>telephone</td> <td>String</td> <td>Telephone number</td> </tr> <tr> <td>identifier</td> <td>String</td> <td>Id or URI (if available)</td> </tr> <tr> <td>openingHours</td> <td>String</td> <td>Opening Hours Specification https://schema.org/OpeningHoursSpecification</td> </tr> <tr> <td>hoursAvailable</td> <td>String</td> <td>Opening Hours restriction</td> </tr> </tbody> </table>	<i>Property</i>	<i>Type</i>	<i>Description</i>	email	String	Email	faxNumber	String	Fax	telephone	String	Telephone number	identifier	String	Id or URI (if available)	openingHours	String	Opening Hours Specification https://schema.org/OpeningHoursSpecification	hoursAvailable	String	Opening Hours restriction
<i>Property</i>	<i>Type</i>	<i>Description</i>																					
email	String	Email																					
faxNumber	String	Fax																					
telephone	String	Telephone number																					
identifier	String	Id or URI (if available)																					
openingHours	String	Opening Hours Specification https://schema.org/OpeningHoursSpecification																					
hoursAvailable	String	Opening Hours restriction																					
<p>Has Channel</p>	<p>Object (0..n)</p>	<p>This property links the Public Service to any Channel through which an Agent provides, uses or otherwise interacts with the Public Service, such as an online service, phone number or office</p> <table border="1" data-bbox="488 1350 1245 1782"> <thead> <tr> <th><i>Property</i></th> <th><i>Type</i></th> <th><i>Description</i></th> </tr> </thead> <tbody> <tr> <td>identifier</td> <td>String</td> <td>Id or URI (if available)</td> </tr> <tr> <td>type</td> <td>String</td> <td>Channel type from controlled vocabulary (see section 4 [2])</td> </tr> <tr> <td>openingHours</td> <td>String</td> <td>Opening Hours Specification</td> </tr> <tr> <td>hoursAvailable</td> <td>String</td> <td>Opening Hours restriction</td> </tr> </tbody> </table>	<i>Property</i>	<i>Type</i>	<i>Description</i>	identifier	String	Id or URI (if available)	type	String	Channel type from controlled vocabulary (see section 4 [2])	openingHours	String	Opening Hours Specification	hoursAvailable	String	Opening Hours restriction						
<i>Property</i>	<i>Type</i>	<i>Description</i>																					
identifier	String	Id or URI (if available)																					
type	String	Channel type from controlled vocabulary (see section 4 [2])																					
openingHours	String	Opening Hours Specification																					
hoursAvailable	String	Opening Hours restriction																					



Processing Time	String (0..1)	The value of this property is the (estimated) time needed for executing a Public Service. The actual information is provided using the ISO8601 syntax for durations.												
Is Described At	Object (0..n)	<p>The property links a Public Service to the Public Service Dataset(s) in which it is being described</p> <table border="1" data-bbox="488 527 1247 821"> <thead> <tr> <th><i>Property</i></th> <th><i>Type</i></th> <th><i>Description</i></th> </tr> </thead> <tbody> <tr> <td>identifier</td> <td>String</td> <td>Id or URI (if available)</td> </tr> <tr> <td>name</td> <td>String</td> <td>Dataset name</td> </tr> <tr> <td>landingPage</td> <td>String</td> <td>Landing page URL where dataset is published</td> </tr> </tbody> </table>	<i>Property</i>	<i>Type</i>	<i>Description</i>	identifier	String	Id or URI (if available)	name	String	Dataset name	landingPage	String	Landing page URL where dataset is published
<i>Property</i>	<i>Type</i>	<i>Description</i>												
identifier	String	Id or URI (if available)												
name	String	Dataset name												
landingPage	String	Landing page URL where dataset is published												

5.4 Service Instance

The following classes and properties collect information about the service instances to be used/invoked internally or externally the ACROSS platform. In particular this section collects information about Technical, Service Provider and Data Controller Descriptions of actual instance where service is deployed.

Table 3 - Service Instance class

Property	Type	Description																																	
serviceProvider	Object (1..1)	Object describing service provider: <table border="1"><thead><tr><th><i>Property</i></th><th><i>Type</i></th><th><i>Description</i></th></tr></thead><tbody><tr><td>businessId</td><td>String</td><td>Business ID</td></tr><tr><td>name</td><td>String</td><td>Name of service provider</td></tr><tr><td>hasAddress</td><td>String</td><td>Address</td></tr><tr><td>postalcode</td><td>String</td><td>Postal code</td></tr><tr><td>city</td><td>String</td><td>City</td></tr><tr><td>state</td><td>String</td><td>State</td></tr><tr><td>country</td><td>String</td><td>Country</td></tr><tr><td>email</td><td>String</td><td>mail</td></tr><tr><td>telephone</td><td>String</td><td>phone</td></tr><tr><td>jurisdiction</td><td>String</td><td>Jurisdiction</td></tr></tbody></table>	<i>Property</i>	<i>Type</i>	<i>Description</i>	businessId	String	Business ID	name	String	Name of service provider	hasAddress	String	Address	postalcode	String	Postal code	city	String	City	state	String	State	country	String	Country	email	String	mail	telephone	String	phone	jurisdiction	String	Jurisdiction
<i>Property</i>	<i>Type</i>	<i>Description</i>																																	
businessId	String	Business ID																																	
name	String	Name of service provider																																	
hasAddress	String	Address																																	
postalcode	String	Postal code																																	
city	String	City																																	
state	String	State																																	
country	String	Country																																	
email	String	mail																																	
telephone	String	phone																																	
jurisdiction	String	Jurisdiction																																	
dataController	Object (1..1)	Object describing Data Controller, the individual or organisation that decides (or controls) the purpose(s) of processing personal data: <table border="1"><thead><tr><th><i>Property</i></th><th><i>Type</i></th><th><i>Description</i></th></tr></thead><tbody><tr><td>piiController</td><td>String</td><td>Name of Data Controller</td></tr><tr><td>organizationName</td><td>String</td><td>Organization name.</td></tr><tr><td>hasContact</td><td>String</td><td>Contact Person.</td></tr><tr><td>hasAddress</td><td>String</td><td>Address</td></tr><tr><td>email</td><td>String</td><td>Email Address.</td></tr><tr><td>telephone</td><td>String</td><td>phone</td></tr></tbody></table>	<i>Property</i>	<i>Type</i>	<i>Description</i>	piiController	String	Name of Data Controller	organizationName	String	Organization name.	hasContact	String	Contact Person.	hasAddress	String	Address	email	String	Email Address.	telephone	String	phone												
<i>Property</i>	<i>Type</i>	<i>Description</i>																																	
piiController	String	Name of Data Controller																																	
organizationName	String	Organization name.																																	
hasContact	String	Contact Person.																																	
hasAddress	String	Address																																	
email	String	Email Address.																																	
telephone	String	phone																																	



connector	Object (0..1)	Object describing the referenced connector proxying an external service. See 0																		
dataset	Object (1..n)	Object Describing the Service Data Description. See 5.6																		
serviceUrls	Object (1..1)	Object collects all information to interact with the internal components (e.g. Consent manager...): <table border="1" data-bbox="712 625 1416 1444"> <thead> <tr> <th><i>Property</i></th> <th><i>Type</i></th> <th><i>Description</i></th> </tr> </thead> <tbody> <tr> <td>libraryDomain</td> <td>String</td> <td>Domain of library to interact with consent manager</td> </tr> <tr> <td>loginUri</td> <td>String</td> <td>Link to login component.</td> </tr> <tr> <td>linkingRedirectUri</td> <td>String</td> <td>Service link to interact with consent manager.</td> </tr> <tr> <td>objectionUri</td> <td>String</td> <td>Service link to interact with consent manager for objection request</td> </tr> <tr> <td>notificationUri</td> <td>String</td> <td>Service link to interact with consent manager for notification request</td> </tr> </tbody> </table>	<i>Property</i>	<i>Type</i>	<i>Description</i>	libraryDomain	String	Domain of library to interact with consent manager	loginUri	String	Link to login component.	linkingRedirectUri	String	Service link to interact with consent manager.	objectionUri	String	Service link to interact with consent manager for objection request	notificationUri	String	Service link to interact with consent manager for notification request
<i>Property</i>	<i>Type</i>	<i>Description</i>																		
libraryDomain	String	Domain of library to interact with consent manager																		
loginUri	String	Link to login component.																		
linkingRedirectUri	String	Service link to interact with consent manager.																		
objectionUri	String	Service link to interact with consent manager for objection request																		
notificationUri	String	Service link to interact with consent manager for notification request																		



5.5 Connector

Table 4 - Connector class

Property	Type	Description															
connectorEndpoint	Object (1..1)	Object describing Service Connector endpoint:															
		<table border="1"> <thead> <tr> <th><i>Property</i></th> <th><i>Type</i></th> <th><i>Description</i></th> </tr> </thead> <tbody> <tr> <td>accessUrl</td> <td>String</td> <td>Access URL of an endpoint.</td> </tr> <tr> <td>endpointInformation</td> <td>String</td> <td>Endpoint description</td> </tr> <tr> <td>endpointDocumentation</td> <td>String</td> <td>URI reference to a documentation of the endpoint, e.g., reference to an OpenAPI-based documentation.</td> </tr> <tr> <td>path</td> <td>String</td> <td>Relative path, topic or queue at which the content is published by the related host.</td> </tr> </tbody> </table>	<i>Property</i>	<i>Type</i>	<i>Description</i>	accessUrl	String	Access URL of an endpoint.	endpointInformation	String	Endpoint description	endpointDocumentation	String	URI reference to a documentation of the endpoint, e.g., reference to an OpenAPI-based documentation.	path	String	Relative path, topic or queue at which the content is published by the related host.
		<i>Property</i>	<i>Type</i>	<i>Description</i>													
		accessUrl	String	Access URL of an endpoint.													
		endpointInformation	String	Endpoint description													
endpointDocumentation	String	URI reference to a documentation of the endpoint, e.g., reference to an OpenAPI-based documentation.															
path	String	Relative path, topic or queue at which the content is published by the related host.															
publicKey	Object (1..1)	Object describing Connector Public Key:															
		<table border="1"> <thead> <tr> <th><i>Property</i></th> <th><i>Type</i></th> <th><i>Description</i></th> </tr> </thead> <tbody> <tr> <td>keyType</td> <td>String</td> <td>Type of Key</td> </tr> </tbody> </table>	<i>Property</i>	<i>Type</i>	<i>Description</i>	keyType	String	Type of Key									
<i>Property</i>	<i>Type</i>	<i>Description</i>															
keyType	String	Type of Key															



		KeyValue	String	Public Key Value
--	--	-----------------	--------	------------------

5.6 Dataset

Table 5 - Dataset class

Property	Type	Description																		
identifier	String (1..1)	Dataset unique identifier.																		
datastructureSpecific ation	String (0..1)	URL pointing to further description of the data (e.g. to JSON schema).																		
dataMapping	Object (1..n)	Array of objects describing the mapping of each data with a personal data concept belonging to a controlled vocabulary: <table border="1" data-bbox="641 1123 1416 1892"> <thead> <tr> <th><i>Property</i></th> <th><i>Type</i></th> <th><i>Description</i></th> </tr> </thead> <tbody> <tr> <td>property</td> <td>string</td> <td>Specific property of the dataset (for example a specific field in a form)</td> </tr> <tr> <td>conceptId</td> <td>string</td> <td>Reference to a concept of a personal data ontology (i.e. DPV)</td> </tr> <tr> <td>type</td> <td>string</td> <td>Type of data ["Text","Video","Image","Audio"]</td> </tr> <tr> <td>required</td> <td>integer</td> <td>If that property is required [True=1, False=0]</td> </tr> <tr> <td>sensitive</td> <td>integer</td> <td>If this personal data is also sensitive [True=1, False=0]</td> </tr> </tbody> </table>	<i>Property</i>	<i>Type</i>	<i>Description</i>	property	string	Specific property of the dataset (for example a specific field in a form)	conceptId	string	Reference to a concept of a personal data ontology (i.e. DPV)	type	string	Type of data ["Text","Video","Image","Audio"]	required	integer	If that property is required [True=1, False=0]	sensitive	integer	If this personal data is also sensitive [True=1, False=0]
<i>Property</i>	<i>Type</i>	<i>Description</i>																		
property	string	Specific property of the dataset (for example a specific field in a form)																		
conceptId	string	Reference to a concept of a personal data ontology (i.e. DPV)																		
type	string	Type of data ["Text","Video","Image","Audio"]																		
required	integer	If that property is required [True=1, False=0]																		
sensitive	integer	If this personal data is also sensitive [True=1, False=0]																		



description	Object (1..n)	Array of localized textual descriptions.												
		<table border="1"> <thead> <tr> <th><i>Property</i></th> <th><i>Type</i></th> <th><i>Description</i></th> </tr> </thead> <tbody> <tr> <td>locale</td> <td>string</td> <td>Language used in information, ISO 639-1 coded</td> </tr> <tr> <td>description</td> <td>string</td> <td>Textual description</td> </tr> <tr> <td>keywords</td> <td>Array[String]</td> <td>Keyword tags related to textual description.</td> </tr> </tbody> </table>	<i>Property</i>	<i>Type</i>	<i>Description</i>	locale	string	Language used in information, ISO 639-1 coded	description	string	Textual description	keywords	Array[String]	Keyword tags related to textual description.
		<i>Property</i>	<i>Type</i>	<i>Description</i>										
		locale	string	Language used in information, ISO 639-1 coded										
		description	string	Textual description										
keywords	Array[String]	Keyword tags related to textual description.												

5.7 Service Personal Data Handling Section

This section It collects the different legal basis and requirements for personal data processing according to EU data protection Rules (Art. 6 GDPR). It describes describe different situations where a company or an organisation is allowed to collect or reuse your personal information: contract, legal obligation, vital interest, public interest, legitimate interest and consent. The following information are used by the consent manager component in the citizen data ownership layer.

Table 6 - Personal Data Handling class

Property	Type	Description
purposeId	String	Purpose's ID, must be unique within the service description
purposeName	String	Human readable Purpose's Name, Short name that identifies the purpose
legalBasis	String	Legal basis in the "processing" of personal Data according to the GDPR: ["Consent", "Contract", "Legal Obligation", "Vital Interest", "Public Interest", "Legitimate Interest"]



purposeCategory	String	Category of purpose from a controlled taxonomy.																		
hasSector	String	Purposes can be further restricted to specific sectors																		
hasSector	String	Purposes can be further restricted to specific contexts																		
processingCategories	String	Category of actions related to a specific purpose and from a controlled taxonomy.																		
description	Object (1..n)	<p>Array of localized description of processing:</p> <table border="1"> <thead> <tr> <th>Property</th> <th>Type</th> <th>Description</th> </tr> </thead> <tbody> <tr> <td>locale</td> <td>string</td> <td>Language used in information, ISO 639-1 coded</td> </tr> <tr> <td>title</td> <td>string</td> <td>Title of processing</td> </tr> <tr> <td>description</td> <td>string</td> <td>Description of the service</td> </tr> <tr> <td>descriptionUrl</td> <td>string</td> <td>Url of the document describing in detail the processing of personal data</td> </tr> <tr> <td>iconUrl</td> <td>string</td> <td>Link of icon identifying the type of processing</td> </tr> </tbody> </table>	Property	Type	Description	locale	string	Language used in information, ISO 639-1 coded	title	string	Title of processing	description	string	Description of the service	descriptionUrl	string	Url of the document describing in detail the processing of personal data	iconUrl	string	Link of icon identifying the type of processing
Property	Type	Description																		
locale	string	Language used in information, ISO 639-1 coded																		
title	string	Title of processing																		
description	string	Description of the service																		
descriptionUrl	string	Url of the document describing in detail the processing of personal data																		
iconUrl	string	Link of icon identifying the type of processing																		



hasPersonalDataCategory	String (1..n)	Indicates which category of personal data is processed from a controlled taxonomy.															
requiredDatasets	String (1..n)	Array listing the required dataset (described previously)															
storage	Object (0..n)	Object describing the type of storage: <table border="1" data-bbox="748 577 1395 724"> <thead> <tr> <th>Property</th> <th>Type</th> <th>Description</th> </tr> </thead> <tbody> <tr> <td>location</td> <td>string</td> <td>Storage Category</td> </tr> <tr> <td>duration</td> <td>string</td> <td>duration</td> </tr> </tbody> </table>	Property	Type	Description	location	string	Storage Category	duration	string	duration						
Property	Type	Description															
location	string	Storage Category															
duration	string	duration															
recipients	String (0..n)	List of type of recipients of personal data processing															
shareWith	Object (0..n)	Array of objects describing with whom the consent permits to share data. Organisation identifies the organisation with whom the data is permitted to share: <table border="1" data-bbox="748 1066 1414 1598"> <thead> <tr> <th>Property</th> <th>Type</th> <th>Description</th> </tr> </thead> <tbody> <tr> <td>orgName</td> <td>string</td> <td>Organization Name</td> </tr> <tr> <td>businessType</td> <td>string</td> <td>Business Type: Profit, No-Profit</td> </tr> <tr> <td>orgUrl</td> <td>string</td> <td>url of organization page</td> </tr> <tr> <td>required</td> <td>boolean</td> <td>It sets if optional or not</td> </tr> </tbody> </table>	Property	Type	Description	orgName	string	Organization Name	businessType	string	Business Type: Profit, No-Profit	orgUrl	string	url of organization page	required	boolean	It sets if optional or not
Property	Type	Description															
orgName	string	Organization Name															
businessType	string	Business Type: Profit, No-Profit															
orgUrl	string	url of organization page															
required	boolean	It sets if optional or not															
obligations	Object (0..n)	Obligations are the actions to be performed when an event occurs. Obligation defines the obligation related to consent, i.e. has an event and an activity and it defines what action to perform when an															



		<p>event related to consent occurs. For example, when the consent expires (event), then re-solicit consent (activity) or when the consent is revoked (event) then stop processing (activity).</p> <table border="1"> <thead> <tr> <th>Property</th> <th>Type</th> <th>Description</th> </tr> </thead> <tbody> <tr> <td>event</td> <td>string</td> <td>Event defines the event based on which an activity is required to do.</td> </tr> <tr> <td>activity</td> <td>string</td> <td>Activity defines what activity is required to do when an event occurs.</td> </tr> </tbody> </table>	Property	Type	Description	event	string	Event defines the event based on which an activity is required to do.	activity	string	Activity defines what activity is required to do when an event occurs.
Property	Type	Description									
event	string	Event defines the event based on which an activity is required to do.									
activity	string	Activity defines what activity is required to do when an event occurs.									
policyRef	String	Reference to related Privacy Policy									
collectionMethod	String	It indicates the method of collection of consent									
CollectionOperator	String	It indicates Operator who collects Consents.									
termination	String	Termination rule of legal basis under which personal data can be processed.									

5.8 Service Data Usage Section

This section provides the reference of one or more usage rules associated to a specific service. The specification of usage rules are defined externally to the service Catalogue.

Table 7 - Data Usage class

Property	Type	Description
usageId	String (1..1)	Usage's ID, must be unique within the service description.
usageName	String (1..1)	Human readable Usage's Name, Short name that identifies the rule.
usageType	String (1..1)	Category of contract agreements from a controlled taxonomy.

5.9 Service Model JSON Schema

In the following the first level of JSON schema adopted by the Service Catalogue in line with the initial Service Model.

```
{
  "title": "ServiceModel",
  "$schema": "http://json-schema.org/draft-04/schema#",
  "type": "object",
  "properties": {
    "title": {
      "type": "string",
      "title": "Service Name",
      "description": "Service Name"
    },
    "identifier": {
      "type": "string",
      "title": "Service Identifier",
      "description": "Service URI if exists"
    },
    "issued": {
      "type": "string",
      "title": "Issued at",
      "description": "Timestamp of the Service creation"
    },
    "createdByUserId": {
      "type": "string",
      "title": "Created by User Id",
      "description": "User Id of Service Editor (e.g. Data Controller)."
    },
    "versionInfo": {
```



```
"type": "string",
"title": "Service Description version",
"description": "Service description version number.",
},
"serviceIconUrl": {
  "type": "string",
  "title": "Service Icon Url",
  "description": "URL pointing to Service Icon file"
},
"status": {
  "type": "string",
  "title": "Service Description status",
  "description": "Status of Service Description (Allowed values: *Completed*, *Deprecate
d*, *UnderDevelopment*, *Withdrawn*),"
  "default": "UnderDevelopment",
  "enum": ["Completed", "Deprecated", "UnderDevelopment", "WithDrawn"],
  "options": { "enum_titles": ["Completed", "Deprecated", "Under Development", "Withdraw
n"] }
},
"isActive": {
  "type": "boolean",
  "title": "Public Service",
  "description": "if public service or not",
  "default": "true"
},
"hasInfo": {
  "$ref": "./service-cpsv-entry.json"
},
"hasServiceInstance": {
  "$ref": "./service_instance.json"
},
"hasUsageRule": {
  "type": "array",
  "title": "Usage Rule",
  "format": "tabs",
  "description": "It collects contract and usage rules for data sharing",
  "items": {
    "$ref": "./usage_rule.json"
  }
},
"isPersonalDataHandling": {
  "type": "array",
  "title": "Personal Data Handling",
  "format": "tabs",
  "description": "It collects the different legal basis and requirements for personal da
ta processing according to EU data protection Rules (Art. 6 GDPR). It describes describe dif
ferent situations where a company or an organisation is allowed to collect or reuse your per
sonal information: contract, legal obligation, vital interest, public interest, legitimate i
nterest and consent",
  "items": {
    "$ref": "./isPersonalDataHandling.json"
  }
}
```



```
}  
  }  
} }
```

5.10 Service Model JSON-LD Context

The following context definitions are used to export Service Description into the JSON-LD semantic model.

```
{  
  "@context": {  
    "isTypeOf": "@type",  
    "id": "@id",  
    "acr": "https://across-h2020.eu/ns/serviceModel",  
    "adms": "http://www.w3.org/ns/adms#",  
    "cpsv": "http://purl.org/vocab/cpsv#",  
    "cv": "http://data.europa.eu/m8g/",  
    "dcat": "http://www.w3.org/ns/dcat#",  
    "dct": "http://purl.org/dc/terms/",  
    "dpv": "https://w3.org/ns/dpv",  
    "eli": "http://data.europa.eu/eli/ontology#",  
    "foaf": "http://xmlns.com/foaf/0.1/",  
    "ids": "https://w3id.org/idsa/core/",  
    "locn": "http://www.w3.org/ns/locn#",  
    "rdfs": "http://www.w3.org/2000/01/rdf-schema#",  
    "schema": "https://schema.org/",  
    "skos": "http://www.w3.org/2004/02/skos/core#",  
    "xsd": "http://www.w3.org/2001/XMLSchema#",  
    "owl": "http://www.w3.org/2002/07/owl",  
    "prov": "https://www.w3.org/ns/prov#",  
    "vcard": "http://www.w3.org/2006/vcard/ns#",  
    "Agent": "dct:Agent",  
    "BusinessEvent": "cv:BusinessEvent",  
    "Channel": "cv:Channel",  
    "Collection": "skos:Collection",  
    "Concept": "skos:Concept",  
    "ContactPoint": "schema:ContactPoint",  
    "Cost": "cv:Cost",  
    "CriterionRequirement": "cv:CriterionRequirement",  
    "Event": "cv:Event",  
    "Evidence": "cv:Evidence",  
    "LegalResource": "eli:LegalResource",  
    "LifeEvent": "cv:LifeEvent",  
    "LinguisticSystem": "dct:LinguisticSystem",  
    "Location": "dct:Location",  
    "OpeningHoursSpecification": "schema:OpeningHoursSpecification",  
    "Output": "cv:Output",
```



```
"Participation": "cv:Participation",
"PublicOrganisation": "cv:PublicOrganisation",
"PublicService": "cpsv:PublicService",
"PublicServiceDataset": "cv:PublicServiceDataset",
"Rule": "cpsv:Rule",
"accessURL": {
  "@id": "dcat:accessURL",
  "@type": "@id"
},
"endpointInformation": {
  "@id": "ids:endpointInformation",
  "@type": "rdfs:Literal"
},
"endpointDocumentation": {
  "@id": "ids:endpointDocumentation",
  "@type": "rdfs:Literal"
},
"path": {
  "@id": "ids:path",
  "@type": "rdfs:Literal"
},
"createdByUserId": {
  "@id": "acr:createdByUserId",
  "@type": "rdfs:Literal"
},
"currency": {
  "@id": "cv:currency",
  "@type": "@id"
},
"connector": {
  "@id": "ids:connector",
  "@type": "@id"
},
"connectorEndpoint": {
  "@id": "ids:hasDefaultEndpoint",
  "@type": "@id"
},
"description": {
  "@id": "dct:description",
  "@type": "rdfs:Literal"
},
"email": {
  "@id": "schema:email",
  "@type": "rdfs:Literal"
},
"fax": {
  "@id": "schema:faxNumber",
  "@type": "rdfs:Literal"
},
"follows": {
  "@id": "cpsv:follows",
  "@type": "@id"
}
```



```
    },
    "follows": {
      "@id": "cpsv:follows",
      "@type": "@id"
    },
    "format": {
      "@id": "dct:format",
      "@type": "@id"
    },
    "hasAddress": {
      "@id": "cv:hasAddress",
      "@type": "@id"
    },
    "hasChannel": {
      "@id": "cv:hasChannel",
      "@type": "@id"
    },
    "hasCompetentAuthority": {
      "@id": "cv:hasCompetentAuthority",
      "@type": "@id"
    },
    "hasContactPoint": {
      "@id": "cv:hasContactPoint",
      "@type": "@id"
    },
    "hasCost": {
      "@id": "cv:hasCost",
      "@type": "@id"
    },
    "hasCriterion": {
      "@id": "cv:hasCriterion",
      "@type": "@id"
    },
    "hasDataController": {
      "@id": "dpv:hasDataController",
      "@type": "@id"
    },
    "hasInput": {
      "@id": "cpsv:hasInput",
      "@type": "@id"
    },
    "hasInfo": {
      "@id": "acr:hasInfo",
      "@type": "@id"
    },
    "hasLegalResource": {
      "@id": "cv:hasLegalResource",
      "@type": "@id"
    },
    "hasPart": {
      "@id": "dct:hasPart",
      "@type": "@id"
    }
  }
```



```
    },
    "hasParticipation": {
      "@id": "cv:hasParticipation",
      "@type": "@id"
    },
    "hasServiceInstance": {
      "@id": "acr:hasServiceInstance",
      "@type": "@id"
    },
    "hoursAvailable": {
      "@id": "schema:hoursAvailable",
      "@type": "@id"
    },
    "iconUrl": {
      "@id": "schema:url",
      "@type": "rdfs:Literal"
    },
    "identifier": {
      "@id": "dct:identifier",
      "@type": "rdfs:Literal"
    },
    "ifAccessedThrough": {
      "@id": "cv:ifAccessedThrough",
      "@type": "@id"
    },
    "implements": {
      "@id": "cpsv:implements",
      "@type": "@id"
    },
    "isClassifiedBy": {
      "@id": "cv:isClassifiedBy",
      "@type": "@id"
    },
    "isDefinedBy": {
      "@id": "cv:isDefinedBy",
      "@type": "@id"
    },
    "isDescribedAt": {
      "@id": "cv:isDescribedAt",
      "@type": "@id"
    },
    "isGroupedBy": {
      "@id": "cv:isGroupedBy",
      "@type": "@id"
    },
    "isPublicService": {
      "@id": "acr:isPublicService",
      "@type": "xsd:boolean"
    },
    "issued": {
      "@id": "dct:issued",
      "@type": "rdfs:Literal"
    }
  },
  "hasParticipation": {
    "@id": "cv:hasParticipation",
    "@type": "@id"
  },
  "hasServiceInstance": {
    "@id": "acr:hasServiceInstance",
    "@type": "@id"
  },
  "hoursAvailable": {
    "@id": "schema:hoursAvailable",
    "@type": "@id"
  },
  "iconUrl": {
    "@id": "schema:url",
    "@type": "rdfs:Literal"
  },
  "identifier": {
    "@id": "dct:identifier",
    "@type": "rdfs:Literal"
  },
  "ifAccessedThrough": {
    "@id": "cv:ifAccessedThrough",
    "@type": "@id"
  },
  "implements": {
    "@id": "cpsv:implements",
    "@type": "@id"
  },
  "isClassifiedBy": {
    "@id": "cv:isClassifiedBy",
    "@type": "@id"
  },
  "isDefinedBy": {
    "@id": "cv:isDefinedBy",
    "@type": "@id"
  },
  "isDescribedAt": {
    "@id": "cv:isDescribedAt",
    "@type": "@id"
  },
  "isGroupedBy": {
    "@id": "cv:isGroupedBy",
    "@type": "@id"
  },
  "isPublicService": {
    "@id": "acr:isPublicService",
    "@type": "xsd:boolean"
  },
  "issued": {
    "@id": "dct:issued",
    "@type": "rdfs:Literal"
  }
}
```



```
},
"keyword": {
  "@id": "dcat:keyword",
  "@type": "rdfs:Literal"
},
"publicKey": {
  "@id": "ids:publicKey",
  "@type": "@id"
},
"keyType": {
  "@id": "ids:keyType",
  "@type": "rdfs:Literal"
},
"keyValue": {
  "@id": "ids:keyValue",
  "@type": "rdfs:Literal"
},
"landingPage": {
  "@id": "dcat:landingPage",
  "@type": "@id"
},
"language": {
  "@id": "dct:language",
  "@type": "@id"
},
"libraryDomain": {
  "@id": "dct:identifier",
  "@type": "rdfs:Literal"
},
"loginUri": {
  "@id": "dct:identifier",
  "@type": "rdfs:Literal"
},
"linkingRedirectUri": {
  "@id": "dct:identifier",
  "@type": "rdfs:Literal"
},
"objectionUri": {
  "@id": "dct:identifier",
  "@type": "rdfs:Literal"
},
"notificationUri": {
  "@id": "dct:identifier",
  "@type": "rdfs:Literal"
},
"member": {
  "@id": "skos:member",
  "@type": "@id"
},
"onBehalf" : {
  "@id": "prov:actedOnBehalfOf",
  "@type": "@id"
}
```



```
    },
    "openingHours": {
      "@id": "schema:openingHours",
      "@type": "rdfs:Literal"
    },
    "operatorName": {
      "@id": "acr:operatorName",
      "@type": "rdfs:Literal"
    },
    "organizationName": {
      "@id": "vcard:organization-name",
      "@type": "rdfs:Literal"
    },
    "ownedBy": {
      "@id": "cv:ownedBy",
      "@type": "@id"
    },
    "page": {
      "@id": "foaf:page",
      "@type": "@id"
    },
    "playsRole": {
      "@id": "cv:playsRole",
      "@type": "@id"
    },
    "prefLabel": {
      "@id": "skos:prefLabel",
      "@type": "rdfs:Literal"
    },
    "processingTime": {
      "@id": "cv:processingTime",
      "@type": "rdfs:Literal"
    },
    "produces": {
      "@id": "cpsv:produces",
      "@type": "@id"
    },
    "publisher": {
      "@id": "dct:publisher",
      "@type": "@id"
    },
    "related": {
      "@id": "dct:relation",
      "@type": "@id"
    },
    "requires": {
      "@id": "dct:requires",
      "@type": "@id"
    },
    "role": {
      "@id": "cv:role",
      "@type": "@id"
    }
  },
  "role": {
    "@id": "cv:role",
    "@type": "@id"
  }
}
```



```
    },
    "sector": {
      "@id": "cv:sector",
      "@type": "@id"
    },
    "serviceProvider": {
      "@id": "acr:serviceProvider",
      "@type": "@id"
    },
    "serviceUrls": {
      "@id": "acr:serviceUrls",
      "@type": "@id"
    },
    "businessId": {
      "@id": "dct:identifier",
      "@type": "rdfs:Literal"
    },
    "name": {
      "@id": "foaf:name",
      "@type": "rdfs:Literal"
    },
    "postalcode": {
      "@id": "schema:postalCode",
      "@type": "rdfs:Literal"
    },
    "city": {
      "@id": "vcard:locality",
      "@type": "rdfs:Literal"
    },
    "state": {
      "@id": "vcard:region",
      "@type": "rdfs:Literal"
    },
    "country": {
      "@id": "vcard:country-name",
      "@type": "rdfs:Literal"
    },
    "jurisdiction": {
      "@id": "eli:jurisdiction",
      "@type": "rdfs:Literal"
    },
    "spatial": {
      "@id": "dct:spatial",
      "@type": "@id"
    },
    "status": {
      "@id": "adms:status",
      "@type": "@id"
    },
    "telephone": {
      "@id": "schema:telephone",
      "@type": "rdfs:Literal"
    }
  },
  "telephone": {
    "@id": "schema:telephone",
    "@type": "rdfs:Literal"
  }
}
```



```
    },
    "thematicArea": {
      "@id": "cv:thematicArea",
      "@type": "@id"
    },
    "title": {
      "@id": "dct:title",
      "@type": "rdfs:Literal"
    },
    "type": {
      "@id": "dct:type",
      "@type": "@id"
    },
    "value": {
      "@id": "cv:value",
      "@type": "xsd:double"
    },
    "versionInfo": {
      "@id": "owv:versionInfo",
      "@type": "http://www.w3.org/2001/XMLSchema#string"
    }
  }
}
```

6 Annex II - Service Catalogue APIs

A Swagger-UI screenshot is reported below (Figure 31), in order to summarize the initial APIs exposed by the Service Catalogue for the management of Service descriptions.



Figure 31 - Documentation of the API of Service Catalogue

Service Catalogue APIs are protected by the Keycloak Oauth2 authorization server. An external client application/service that wants to interact with Service Catalogue by using the APIs, must perform one of the available OAuth2 flows (Authorization Code, Client Credentials and Password grants) against the Keycloak IdM, in order to get an Access Token and then use it in the API requests.



7 Annex III - ACROSS Requirements Mapping

Id	Title	Description	Type	Category
Req_01	Semantic and technical interoperability with SDG	The system should ensure an alignment of semantic and technical interoperability with SDG IT Tools	non functional	Platform architecture and interoperability
Req_09	Free access to other countries' e-services	As a user I want to be able to access other countries' services	non functional	Platform architecture and interoperability
Req_13	Interoperability with legacy systems	It has to be possible to connect the ACROSS platform with the existent PA legacy systems (e.g. databases, web services). Secure and reliable communication with the existing public administration information systems have to be provided without requiring changes in these systems. The platform should also provide tools and predefined components to facilitate the interoperability.	non functional	Platform architecture and interoperability
Req_15	Easy to use service integration and orchestration tools	In order to create cross border services the platform has to support Public and Private providing a set of tools and applications that will help them to easily implement service integration.	functional	Connectors to integrate the private and public sector offering
Req_16	Open API access	Data and services available in the ACROSS platform have to be accessible via a set of APIs using standardized approaches(e.g. RESTful API).	functional	Platform architecture and interoperability



Req_17	Service Registries	ACROSS platform has to maintain registries of all available services offered by different PAs, SMEs and by the platform itself. Every service should be well-described using standard metamodels	functional	Connectors to integrate the private and public sector offering
Req_18	Cross Border Authentication	The services deployed and executed in ACROSS platform should have the possibility to be integrated, if needed, with eIDAS system. The platform can optionally support single-sign-on mechanism to simplify authentication on multiple applications and services internally to the platform.	functional	Security and Privacy
Req_19	Reliability and Integrity	The implementation of ACROSS should follow open standards and use well-known and widely accepted technologies in order to ensure integrity. The ACROSS platform has to be reliable assuring integrity of the components/tools that are part of it.	non functional	Platform architecture and interoperability
Req_20	Security access	Access to services and data has to be available to authorized users/applications only. Only audited applications are allowed to be deployed to ensure compliance with the security policies. Every security violation should be reported and the necessary actions to protect information and applications present in the platform has to be performed.	functional	Security and Privacy



Req_27	Catalogue of services (public/private) data model	The Catalogue of services data model will follow the common public core vocabularies coming from ISA2 and the EIF implementation regulation and will support interoperability with SDG	functional	Platform architecture and interoperability
Req_28	Catalogue of services (public/private) objective	The catalogue of services will take care of harmonisation of the private and public services and related data enabling semantic interoperability and supporting the selected common vocabularies should be used to express the metadata.	functional	Platform architecture and interoperability
Req_29	No vendor lock-in	I want the ACROSS reference architecture to be technologically agnostic to avoid vendor lock-in.	non functional	Platform architecture and interoperability
Req_30	Open source	I want the ACROSS reference architecture to reuse already available open source solutions and only create or improve those aspects that are not covered by the existing solutions	non functional	Platform architecture and interoperability
Req_35	Usability and adaptability	The provided solutions in the platform should be user-friendly and easy to use and should be multilingual. No piece of text that might be displayed to a user shall reside in source code and solution and user should be able to select the preferred language . The implementation of the system should follow open standards and use well-known and widely accepted technologies in order to ensure ease of use.	non functional	Platform architecture and interoperability



Req_36	Minimal browser support.	The component user interface (where available e.g. dashboards, forms, etc...) should provide support for the wide range of widely used browsers.	non functional	Web&Mobile applications
---------------	--------------------------	--	----------------	-------------------------